

AIR TOOLS CATALOG

shinano

VOL.01

- IMPACT WRENCHES ■ DRIVERS ■ RATCHET WRENCHES
- SANDERS ■ POLISHERS ■ GRINDERS ■ DRILLS / SPOTMILLS
- CUTTING TOOLS ■ OTHERS



 PNEUMATIC TOOLS
SHINANO INC.

<http://www.shinanoinc.com/>



CENTRALA TECHNICZNA
ELTECH 

Twój dystrybutor:

Centrala Techniczna ELTECH Sp. z o.o.
ul. Fabryczna 1-3, 58-100 Świdnica

tel. 74 858 27 00 fax 74 858 27 01

eltech@eltech.com.pl www.eltech.com.pl

 PNEUMATIC TOOLS
SHINANO INC.

MADE IN JAPAN

Functional and Sophisticated Design

Well designed tools that have fully biotechnological and easy to use.

Highest Perfection

We provide excellence to our customers' needs, in all respects, such as quality, function, user friendliness, safety, noise control and warranty.

That is our promise of having "SI" marked products.



ISO9001
Management system certificate



We, Shinano Inc. were established in 1949 and Specialized our air tools in 1969. We have achieved excellent results and built on our experience to meet our own requirements for quality, accuracy, safety and user friendliness. Our production ratio is one of the largest in the world. We cover more than 100 types of tools.



05-13

IMPACT WRENCHES

1/4" SQ.DR.	06
SI-1310S	06
3/8" SQ.DR.	06-07
SI-1305	06
SI-1315S	06
SI-1355	06
SI-1356	06
SI-1365	06
SI-1605	07
SI-1605SR	07
1/2" SQ.DR.	07-09
SI-1456	07
SI-1650AH	07
SI-1610	08
SI-1610SR	08
SI-1420T	08
SI-1422T	08
SI-1490A	09
SI-1490ASR	09
SI-1492A	09
SI-1492ASR	09
3/4" SQ.DR.	10
SI-1550	10
SI-1550SR	10
SI-1556	10
SI-1556SR	10
1" SQ.DR.	11-12
SI-1700	11
SI-1706	11
SI-1760T	11
SI-1766T	11
SI-1770T	12
SI-1776T	12
SI-1850B	12
SI-1856B	12
ACCESSORIES	13

IMPACT WRENCHES

14-16

DRIVERS

IMPACT DRIVERS	15
SI-1052	15
SI-1060	15
SI-1062	15
SI-1065	15
SI-1070	15
SI-1356D	15
SI-1365D	15
SCREW DRIVERS	16
SI-1140	16
SI-1161	16
SI-1166A	16
SI-1166-8A	16
SI-1170	16
ACCESSORIES	16

DRIVERS

17-20

RATCHET WRENCHES

1/4" SQ.DR.	18
SI-1107B	18
SI-1200B	18
SI-1207	18
SI-1251	18
3/8" SQ.DR.	18-20
SI-1108B	18
SI-1205B	18
SI-1208	19
SI-1252	19
SI-1261/SI-1261S	19
SI-1320A	19
SI-1340B	19
SI-1241A	20
1/2" SQ.DR.	20
SI-1262/SI-1262S	20
SI-1325A	20
SI-1345B	20
SI-1435	20
HEX17mm Through	20
SI-1288	20

RATCHET WRENCHES

21-32

SANDERS

BELT SANDERS	22
SI-2700	22
SI-2700L/SI-2700LS	22
SI-2800	22
SI-2830	22
BELT SANDER ACCESSORIES	22
SANDERS	23-26
SI-3100/SI-3100M	23
SI-3101/SI-3101M	23
SI-3111/SI-3111M	23
SI-3101-6/SI-3101-6M	23
SI-3111-6/SI-3111-6M	23
SI-3103A/SI-3103AM	24
SI-3113A/SI-3113AM	24
SI-3103-6A/SI-3103-6AM	24
SI-3113-6A/SI-3113-6AM	24
SI-3105A/SI-3105AM	24
SI-3105-6A/SI-3105-6AM	24
SI-3118/SI-3118M	25
SI-3118-6/SI-3118-6M	25
SI-3005	25
SI-3007/SI-3007M	25
SI-3115R	25
SI-3115R-6	25
SI-3001A/SI-3001AM	26
SI-3011A/SI-3011AM	26
SI-3003A/SI-3003AM	26
SI-3013A/SI-3013AM	26
SI-3018A/SI-3018AM	26

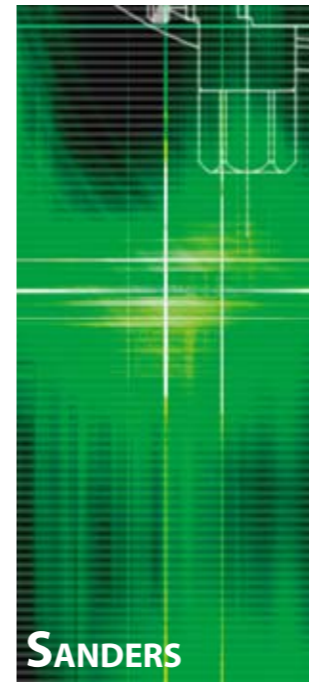
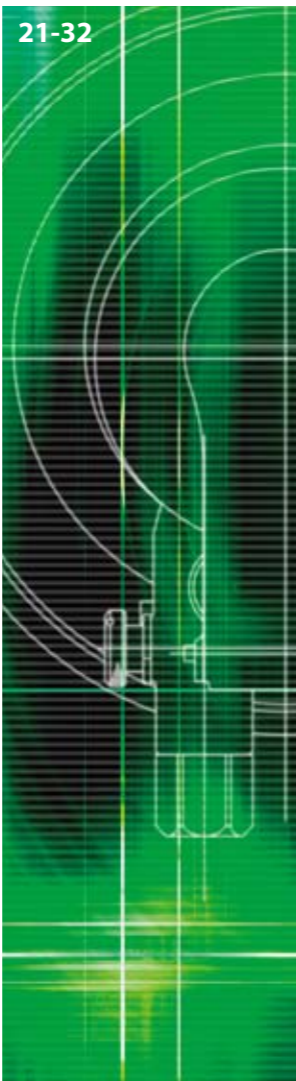

SANDERS

MINI SANDERS	27-28
SI-3102M	27
SI-3112M	27
SI-2007A	27
SI-2008	27
SI-2107A	27
SI-2108	27
SI-2110	28
DISC SANDERS	28-29
SI-2202	28
SI-2201	28
SI-2210	28
SI-2300	28
SI-2026	29
SI-2351	29
OSCILLATION SANDERS	29
SI-3200A	29
SI-3300S	29
WET SANDERS	29
SI-2322WR	29
SI-2322WR-E	29
ACCESSORIES	30-32

33-35

POLISHERS

GEARED DUAL ACTION POLISHERS	34
SI-2415	34
DUAL ACTION POLISHERS	34
SI-3100P	34
SINGLE ACTION POLISHERS	34-35
SI-2221	34
SI-2224S	34
SI-2400	34
SI-2405	34
SI-2451	34
SI-2009	35
SI-2009H	35
ACCESSORIES	35

POLISHERS

36-39

GRINDERS

DIE GRINDERS	37
SI-2001S/SI-2001S-6	37
SI-2002/SI-2002-6	37
SI-2015A/SI-2015A-6	37
SI-2006S/SI-2006S-6	37
SI-2005/SI-2005-6	37
SI-2010/SI-2010-6	38
SI-2011S/SI-2011S-6	37
SI-2012/SI-2012-6	37
CUT OFF GRINDERS	37
SI-2033	37
DIE GRINDERS	38
SI-2022S/SI-2022S-6	38
SI-2023/SI-2023-6	38
DISC GRINDERS	38-39
SI-2501L/SI-2501	38
SI-2500L/SI-2500	38
SI-2515LA	38
SI-2505L	38
SI-2600L	39
MICRO GRINDERS	39
SI-2050AG	39
SI-2051SG	39
ACCESSORIES	39

GRINDERS

40-43

DRILLS/ SPOTMILLS

DRILLS	41-43
SI-2015AD	41
SI-5100A	41
SI-5200A	41
SI-5300A	41
SI-5305A	41
SI-5305-8A	41
SI-5501	42
SI-5506	42
SI-5405	42
SI-5405-6	42
SI-5500	42
SI-5505	42
SI-5355	43
SPOT MILLS	43
SI-5800	43
SI-5850	43
ACCESSORIES	43

DRILLS / SPOTMILLS

44-46

CUTTING TOOLS

SAWS	45
SI-4700B	45
SI-4710/SI-4710F	45
SI-4730	45
SI-4740	45
OSCILLATION CUTTER	45
SI-4300	45
NIBBLER	45
SI-4600	45
SHEAR	46
SI-4500	46
TRIMMER	46
SI-2018A	46
ACCESSORIES	46

CUTTING TOOLS

47-49

OTHERS

AIR HAMMER	48
SI-4120A	48
AIR HAMMERS ACCESSORIES	48
NEEDLE SCALER	49
SI-4150	49
HYDRO PUNCHER	49
SI-4800	49
OTHERS ACCESSORIES	49

OTHERS

50

MAINTENANCE CHECK

51

QUALITY

52-54

ACCESSORIES

IMPACT WRENCHES

IMPACT WRENCHES / 1/4" IMPACT WRENCHES • 3/8" IMPACT WRENCHES

SI-1310S 1/4" Impact Wrench

- **Maximum Torque : 40Nm**
- Composite body absorbs the vibration remarkably well and also protects your hand from the cold.
- Compact, lightweight, and a "feather touch" trigger for easy operation.
- Rear exhaust from handle-end directs air away from operator and workplace.

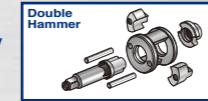
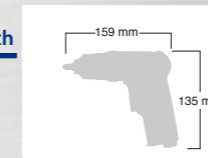

SI-1305 3/8" Impact Wrench

- **Maximum Torque:90Nm**
- 3/8" sq.palm grip Impact with butterfly throttle lever for quick and easy single hand operation
- 360° Air inlet swivel for easy manoeuvring

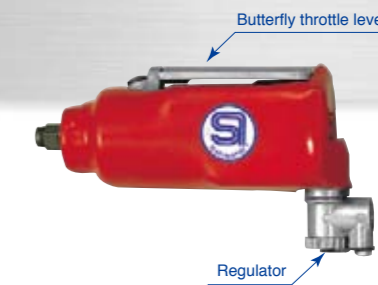
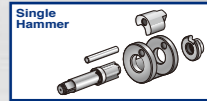
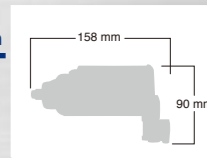

SI-1315S 3/8" Impact Wrench

- **Maximum Torque : 60Nm**
- Composite body absorbs the vibration remarkably well and also protects your hand from the cold.
- Compact, lightweight, and a "feather touch" trigger for easy operation.
- Rear exhaust from handle-end directs air away from operator and workplace.

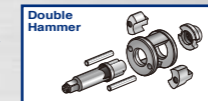
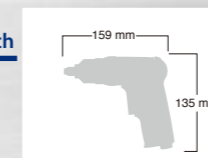

SI-1355 3/8" Impact Wrench

- **Maximum Torque:90Nm**
- Standard impact wrench with front exhaust
- Push button action for reverse

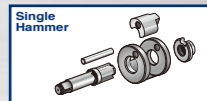
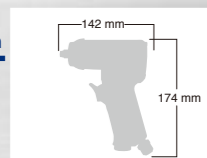

SI-1356 3/8" Impact Wrench

- **Maximum Torque:180Nm**
- A one piece polymer body combined with a pin clutch
- Compact and light weight with high torque

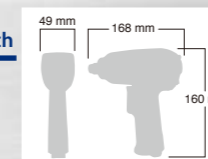

SI-1365 3/8" Impact Wrench

- **Maximum Torque:100Nm**
- The ultimate design for a 3/8" sq drive impact wrench
- Precision machined air motor for durability
- Muffled exhaust for industrial use

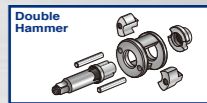
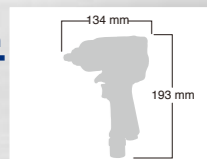

08 458-58 ★

Model Number	Maximum Torque Nm/(ft-lb)	Working Torque Range Nm/(ft-lb)	Bolt Cap mm/(in.)	Free Speed rpm	Weight kg/(lb)	Over Length mm/(in.)	Noise Level dBA/(power)	Vibration m/s ²	Avg.Air Consumption CFM	Air Inlet Size in.	Hose Size mm/(in.)	Clutch Type
SI-1310S	40/(30)	0-35/(0-26)	8/(5/16)	10,000	0.63/(1.39)	159/(6.26)	82/(95)	< 2.5	2.1	1/4	10/(3/8)	Double Hammer
SI-1305	90/(66)	0-75/(0-55)	10/(3/8)	10,000	0.94/(2.08)	158/(6.20)	98/(111)	7.4	2.8	1/4	10/(3/8)	Single Hammer
SI-1315S	60/(44)	0-50/(0-37)	10/(3/8)	10,000	0.63/(1.39)	159/(6.26)	82/(95)	< 2.5	2.1	1/4	10/(3/8)	Double Hammer
SI-1355	90/(66)	0-75/(0-55)	10/(3/8)	9,000	1.12/(2.47)	142/(5.57)	89/(102)	3.1	2.7	1/4	10/(3/8)	Single Hammer
SI-1356	180/(133)	0-150/(0-111)	10/(3/8)	8,000	1.10/(2.43)	168/(6.61)	84/(97)	3.3	3.6	1/4	10/(3/8)	Pin Clutch
SI-1365	100/(74)	0-80/(0-59)	10/(3/8)	9,000	1.31/(2.89)	134/(5.28)	83/(96)	3.3	3.3	1/4	10/(3/8)	Double Hammer

SI-1605 3/8" Impact Wrench

- **Maximum Torque : 350Nm**
- Rubber grip absorbs the vibration remarkably well and also protects your hand from the cold.
- Ergonomic design, compact, and lightweight for easy operation.
- Muffler reduces noise level.

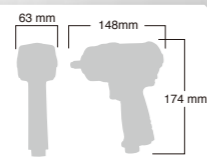

SI-1605SR 3/8" Impact Wrench

- **Maximum Torque : 350Nm**
- Rubber grip absorbs the vibration remarkably well and also protects your hand from the cold.
- Ergonomic design, compact, and lightweight for easy operation.
- Full power in reverse helps to unfasten bolts quickly for changing wheels

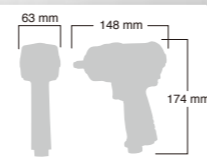

SI-1456 1/2" Impact Wrench

- **Maximum Torque:220Nm**
- Features a one piece polymer body and newly designed pin clutch for light weight and high torque
- Compact design for narrow space

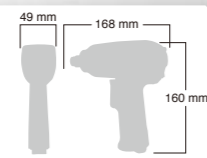

SI-1650AH 1/2" Impact Wrench

- **Maximum Torque:350Nm**
- 90°head model
- Possible to turn the head 360°
- Ideal for changing the blade of tractors and farming equipment

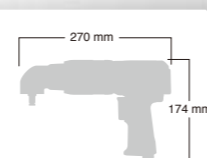

SI-1610 1/2" Impact Wrench

- **Maximum Torque : 450Nm**
- Rubber grip absorbs the vibration remarkably well and also protects your hand from the cold.
- Ergonomic design, compact, and lightweight for easy operation.
- Muffler reduces noise level.

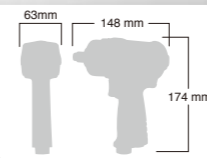

SI-1610SR 1/2" Impact Wrench

- **Maximum Torque : 450Nm**
- Rubber grip absorbs the vibration remarkably well and also protects your hand from the cold.
- Ergonomic design, compact, and lightweight for easy operation.
- Full power in reverse helps to unfasten bolts quickly for changing wheels

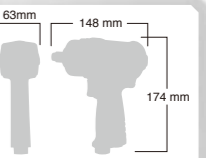

SI-1420T 1/2" Impact Wrench

- **Maximum Torque:500Nm**
- Higher powered impact wrench with 1/2"sq. anvil
- The double hammer clutch delivers higher torque and faster power delivery

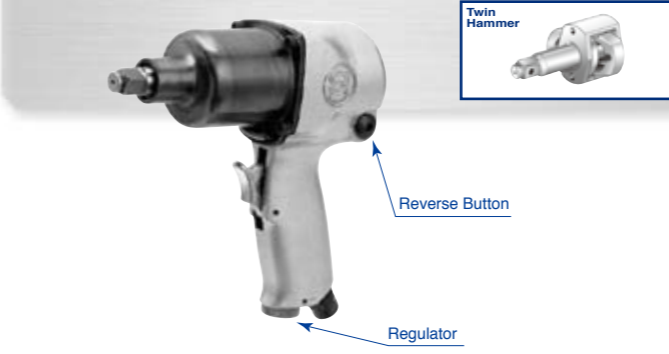
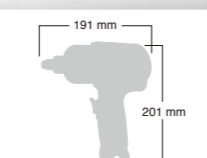

SI-1422T 1/2" Impact Wrench

- **Maximum Torque:480Nm**
- The same quality features of SI-1432T with 2" extended anvil

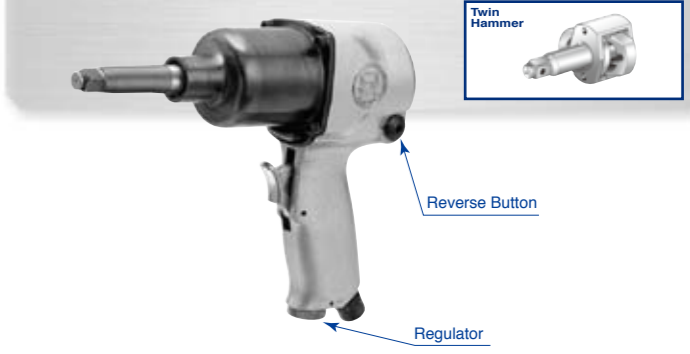
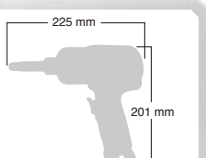

Model Number	Maximum Torque Nm/(ft-lb)	Working Torque Range Nm/(ft-lb)	Bolt Cap mm/(in.)	Free Speed rpm	Weight kg/(lb)	Over Length mm/(in.)	Noise Level dBA/(power)	Vibration m/s ²	Avg.Air Consumption CFM	Air Inlet Size in.	Hose Size mm/(in.)	Clutch Type
SI-1605	350/(258)	0-280/(0-207)	16/(5/8)	(F)8,000 (R)8,500	1.03/(2.27)	148/(5.83)	89/(102)	4.0	3.8	1/4	10/(3/8)	Twin Hammer
SI-1605SR	350/(258)	0-280/(0-207)	16/(5/8)	(F)8,000 (R)8,500	1.03/(2.27)	148/(5.83)	89/(102)	4.0	3.8	1/4	10/(3/8)	Twin Hammer
SI-1456	220/(162)	0-180/(0-133)	16/(5/8)	8,000	1.13/(2.49)	168/(6.61)	84/(97)	4.3	3.6	1/4	10/(3/8)	Pin Clutch
SI-1650AH	350/(258)	0-280/(0-207)	16/(5/8)	(F)7,500 (R)8,000	2.80/(6.17)	270/(10.6)	83/(96)	9.4	4.0	1/4	10/(3/8)	Twin Hammer

Model Number	Maximum Torque Nm/(ft-lb)	Working Torque Range Nm/(ft-lb)	Bolt Cap mm/(in.)	Free Speed rpm	Weight kg/(lb)	Over Length mm/(in.)	Noise Level dBA/(power)	Vibration m/s ²	Avg.Air Consumption CFM	Air Inlet Size in.	Hose Size mm/(in.)	Clutch Type
SI-1610	450/(332)	0-320/(0-258)	18/(11/16)	(F)8,000 (R)8,500	1.04/(2.29)	148/(5.83)	89/(102)	4.0	3.8	1/4	10/(3/8)	Twin Hammer
SI-1610SR	450/(332)	0-320/(0-258)	18/(11/16)	(F)8,000 (R)8,500	1.04/(2.29)	148/(5.83)	89/(102)	4.0	3.8	1/4	10/(3/8)	Twin Hammer
SI-1420T	500/(369)	0-400/(0-295)	18/(11/16)	6,000	2.55/(5.62)	191/(7.52)	96/(108)	3.2	4.0	1/4	10/(3/8)	Twin Hammer
SI-1422T	480/(354)	0-360/(0-266)	18/(11/16)	6,000	2.64/(5.82)	225/(8.86)	96/(108)	3.8	4.0	1/4	10/(3/8)	Twin Hammer

IMPACT WRENCHES / 1/2" IMPACT WRENCHES

★ : Attachment Included
☆ : Accessories

NEW SI-1490A 1/2" Impact Wrench

- **Maximum Torque: 850Nm**
- Rubber grip absorbs the vibration remarkably well and also protects your hand from the cold.
- Light weight body design and easy to operate feather touch trigger.
- Handle grip exhaust directs air away from operator and workplace.
- 4 positions regulator dial for easy adjustment and it has an forward, reverse lever for easy adjustment.

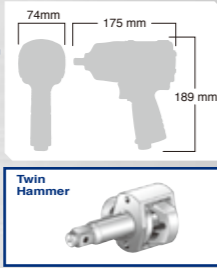

NEW SI-1490ASR 1/2" Impact Wrench

- **Maximum Torque: 850Nm**
- Rubber grip absorbs the vibration remarkably well and also protects your hand from the cold.
- Light weight body design and easy to operate feather touch trigger.
- Handle grip exhaust directs air away from operator and workplace.
- 4 positions regulator dial for easy adjustment and it has an forward, reverse lever for easy adjustment.

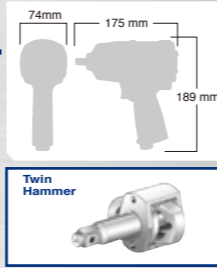

NEW SI-1492A 1/2" Impact Wrench

- **Maximum Torque: 830Nm**
- The same quality features of SI-1490A with 2" extended anvil

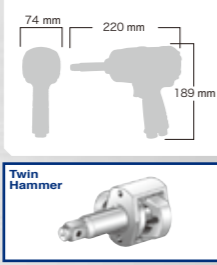

NEW SI-1492ASR 1/2" Impact Wrench

- **Maximum Torque: 830Nm**
- The same quality features of SI-1490ASR with 2" extended anvil

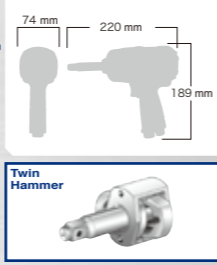

3/4" IMPACT WRENCHES

★ : Attachment Included
☆ : Accessories

SI-1550 3/4" Impact Wrench

- **Maximum Torque: 1,650Nm**
- Rubber grip absorbs the vibration remarkably well and also protects your hand from the cold.
- Easy to operate feather touch trigger.
- Handle grip exhaust directs air away from operator and work place.
- 4 positions regulator dial for easy adjustment and it has an forward, reverse for easy adjustment.

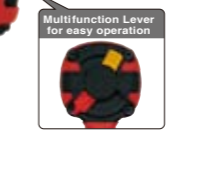
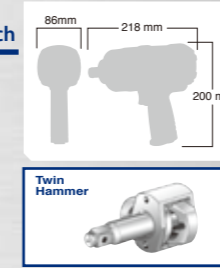

SI-1550SR 3/4" Impact Wrench

- **Maximum Torque: 1,650Nm**
- Rubber grip absorbs the vibration remarkably well and also protects your hand from the cold.
- Easy to operate feather touch trigger.
- Handle grip exhaust directs air away from operator and work place.
- 4 positions regulator dial for easy adjustment and it has an forward, reverse for easy adjustment.

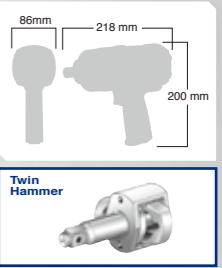

SI-1556 3/4" Impact Wrench

- **Maximum Torque: 1,550Nm**
- Rubber grip absorbs the vibration remarkably well and also protects your hand from the cold.
- Easy to operate feather touch trigger.
- Handle grip exhaust directs air away from operator and work place.
- 4 positions regulator dial for easy adjustment and it has an forward, reverse for easy adjustment.

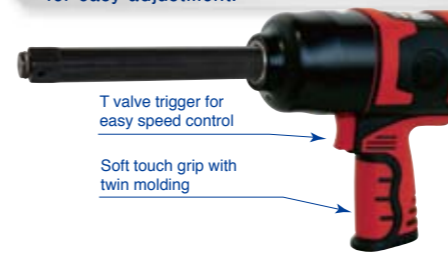
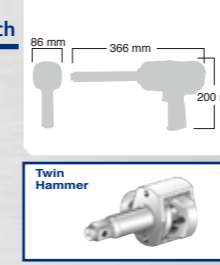

SI-1556SR 3/4" Impact Wrench

- **Maximum Torque: 1,550Nm**
- Rubber grip absorbs the vibration remarkably well and also protects your hand from the cold.
- Easy to operate feather touch trigger.
- Handle grip exhaust directs air away from operator and work place.
- 4 positions regulator dial for easy adjustment and it has an forward, reverse for easy adjustment.

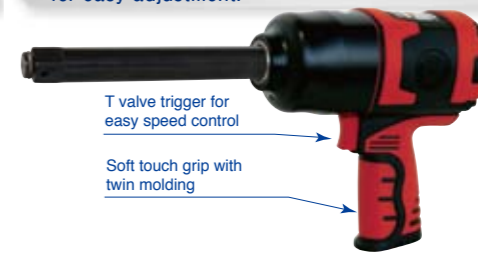
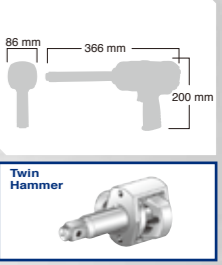

Model Number	Maximum Torque Nm/(ft-lb)	Working Torque Range Nm/(ft-lb)	Bolt Cap mm/(in.)	Free Speed rpm	Weight kg/(lb)	Over Length mm/(in.)	Noise Level dBA/(power)	Vibration m/s ²	Avg. Air Consumption CFM	Air Inlet Size in.	Hose Size mm/(in.)	Clutch Type
SI-1490A	850/(627)	0-620/(0-457)	20/(3/4)	(F)8,000 (R)8,500	1.9/(4.19)	175/(6.89)	91/(104)	4.8	5.1	1/4	10/(3/8)	Twin Hammer
SI-1490ASR	850/(627)	0-620/(0-457)	20/(3/4)	(F)8,000 (R)8,500	1.9/(4.19)	175/(6.89)	91/(104)	4.8	5.1	1/4	10/(3/8)	Twin Hammer
SI-1492A	830/(612)	0-600/(0-443)	20/(3/4)	(F)8,000 (R)8,500	1.94/(4.28)	225/(8.86)	91/(104)	5.8	5.1	1/4	10/(3/8)	Twin Hammer
SI-1490ASR	830/(612)	0-600/(0-443)	20/(3/4)	(F)8,000 (R)8,500	1.94/(4.28)	225/(8.86)	91/(104)	5.8	5.1	1/4	10/(3/8)	Twin Hammer

Model Number	Maximum Torque Nm/(ft-lb)	Working Torque Range Nm/(ft-lb)	Bolt Cap mm/(in.)	Free Speed rpm	Weight kg/(lb)	Over Length mm/(in.)	Noise Level dBA/(power)	Vibration m/s ²	Avg. Air Consumption CFM	Air Inlet Size in.	Hose Size mm/(in.)	Clutch Type
SI-1550	1,650/(1,217)	0-1,320/(0-974)	24/(15/16)	(F)6,000 (R)6,500	3.25/(7.7)	218/(8.58)	101/(114)	9.1	8.0	3/8	13/(1/2)	Twin Hammer
SI-1550SR	1,650/(1,217)	0-1,320/(0-974)	24/(15/16)	(F)6,000 (R)6,500	3.25/(7.7)	218/(8.58)	101/(114)	9.1	8.0	3/8	13/(1/2)	Twin Hammer
SI-1556	1,550/(1,143)	0-1,240/(0-915)	24/(15/16)	(F)6,000 (R)6,500	3.95/(8.71)	366/(14.4)	101/(114)	9.1	8.0	3/8	13/(1/2)	Twin Hammer
SI-1556SR	1,550/(1,143)	0-1,240/(0-915)	24/(15/16)	(F)6,000 (R)6,500	3.95/(8.71)	366/(14.4)	101/(114)	9.1	8.0	3/8	13/(1/2)	Twin Hammer

IMPACT WRENCHES
DRIVERS
RATCHET WRENCHES
SANDERS
POLISHER
GRINDERS
MILLS
CUTTING TOOLS
OTHERS
MAINTENANCE CHECK
QUALITY
ACCESSORIES

SI-1700 1" Impact Wrench

- **Maximum Torque:2,000Nm**
- Light weight straight shape body impact wrench with 1"sq. anvil
- Pin clutch system makes a big torque and low vibration

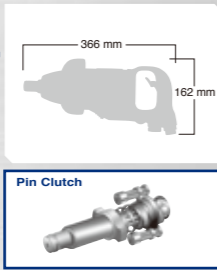

SI-1706 1" Impact Wrench

- **Maximum Torque:1,900Nm**
- 6" extended anvil for SI-1700

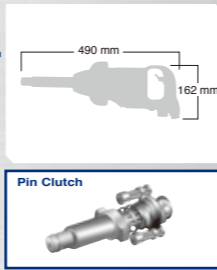

SI-1760T 1" Impact Wrench

- **Maximum Torque:2,200Nm**
- Pistol grip impact wrench with 1"sq. anvil
- A newly designed impact wrench featuring a compact body and powerful twin hammer clutch
- The twin hammer clutch delivers higher torque and quick response

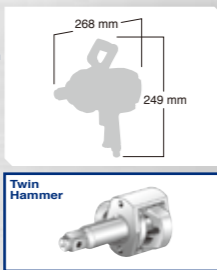

SI-1766T 1" Impact Wrench

- **Maximum Torque:2,160Nm**
- The same quality features of SI-1760T with 6" extended anvil
- Reach into deep truck wheels easily

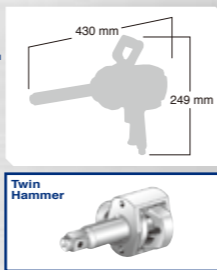

ACCESSORIES ☆

SI-1770T 1" Impact Wrench

- **Maximum Torque:2,300Nm**
- Straight body impact wrench with 1" sq. anvil and D handle
- The twin hammer clutch delivers higher torque and fast power delivery
- Compact body design for reduced weight

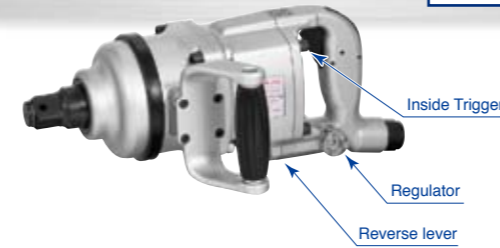
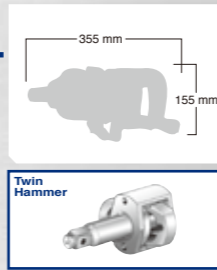

SI-1776T 1" Impact Wrench

- **Maximum Torque:2,200Nm**
- The same quality features of SI-1770T with 6" extended anvil

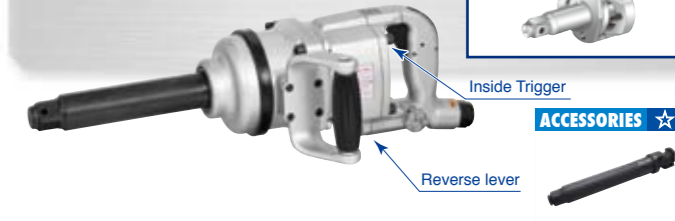
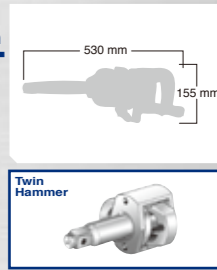

SI-1850B 1" Impact Wrench

- **Maximum Torque:1,600Nm**
- Straight body impact wrench with 1" sq. anvil and D handle
- Original model with a single hammer clutch for reliability
- 38mm Capacity

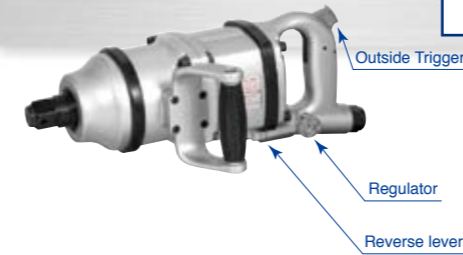
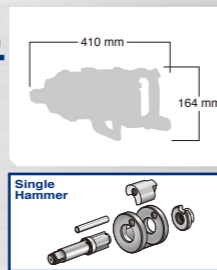

SI-1856B 1" Impact Wrench

- **Maximum Torque:1,500Nm**
- The same quality features of SI-1850B with 6" extended anvil

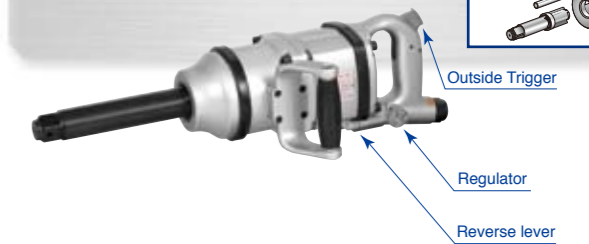
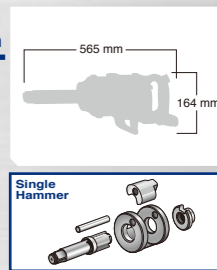

Model Number	Maximum Torque Nm/(ft-lb)	Working Torque Range Nm/(ft-lb)	Bolt Cap mm/(in.)	Free Speed rpm	Weight kg/(lb)	Over Length mm/(in.)	Noise Level dBA/(power)	Vibration m/s ²	Avg. Air Consumption CFM	Air Inlet Size in.	Hose Size mm/(in.)	Clutch Type
SI-1700	2,000/(1,480)	0-1,600/(0-1,180)	38/(1-1/2)	(F)4,500 (R)5,000	7.40/(16.3)	366/(14.4)	101/(114)	7.0	10.5	1/2	13/(1/2)	Pin Clutch
SI-1706	1,900/(1,400)	0-1,500/(0-1,110)	38/(1-1/2)	(F)4,500 (R)5,000	8.40/(18.5)	490/(19.3)	101/(114)	7.3	10.5	1/2	13/(1/2)	Pin Clutch
SI-1760T	2,200/(1,620)	0-1,650/(0-1,220)	38/(1-1/2)	5,000	8.13/(17.9)	268/(10.6)	101/(114)	7.6	13.3	1/2	13/(1/2)	Twin Hammer
SI-1766T	2,160/(1,590)	0-1,600/(0-1,180)	38/(1-1/2)	5,000	8.56/(18.8)	430/(16.9)	101/(114)	8.4	13.3	1/2	13/(1/2)	Twin Hammer

Model Number	Maximum Torque Nm/(ft-lb)	Working Torque Range Nm/(ft-lb)	Bolt Cap mm/(in.)	Free Speed rpm	Weight kg/(lb)	Over Length mm/(in.)	Noise Level dBA/(power)	Vibration m/s ²	Avg. Air Consumption CFM	Air Inlet Size in.	Hose Size mm/(in.)	Clutch Type
SI-1770T	2,300/(1,700)	0-1,700/(0-1,250)	38/(1-1/2)	5,000	8.44/(18.6)	355/(14.0)	100/(113)	8.6	12.3	1/2	13/(1/2)	Twin Hammer
SI-1776T	2,200/(1,620)	0-1,650/(0-1,220)	38/(1-1/2)	5,000	8.87/(19.6)	530/(20.9)	100/(113)	8.8	12.3	1/2	13/(1/2)	Twin Hammer
SI-1850B	1,600/(1,180)	0-1,400/(0-1,030)	38/(1-1/2)	4,000	10.9/(24.0)	410/(16.1)	102/(114)	6.2	14.0	1/2	13/(1/2)	Single Hammer
SI-1856B	1,500/(1,110)	0-1,200/(0-885)	38/(1-1/2)	4,000	12.3/(27.1)	565/(22.2)	102/(114)	7.6	13.7	1/2	13/(1/2)	Single Hammer

103-1

Muffler



01

911P-25

Muffler



02

215RA-13

Muffler with Filter inside
(quieter than 911P-25)



03

911A-15

Muffler Retainer



04

736-8

Muffler Retainer



05

911P-11

Retainer



06

736DH-10

Retainer



07

458-58

Housing Cover



08

EXPLANATION OF CLUTCH

Single Hammer

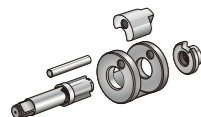

One hammer makes one impact per rotation. This means greater hitting power, long life and easy maintenance.

Double Hammer

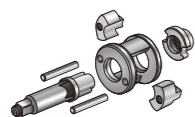

Two hammers make two impacts per rotation. Two hammers of the same form as a single hammer are held. There is little vibration and high torque is obtained than single hammer.

Twin Hammer



Two hammers make one impact per rotation. This design is the most durable of hammer designs and lighter, less vibration, producing a powerful impact.

Roller Clutch

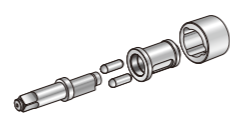

One hammer makes one impact per rotation. It has the characteristic of a single hammer that produce a high torque per one impact and has the characteristics of the double hammer of the numerous impacts per minute.

Pin Clutch



One hammer makes one impact per rotation. Rotating mechanism in which the round hammer pins move up and down, engaging the anvil and producing a powerful impact. It produce higher torque with minimum vibration.

DRIVERS

DRIVERS / IMPACT DRIVERS

★ : Attachment Included
☆ : Accessories

SI-1052 Impact Driver

- More powerful than SI-1051
- Have regulator built-in
- Compact body design for reduce weight and easy operation

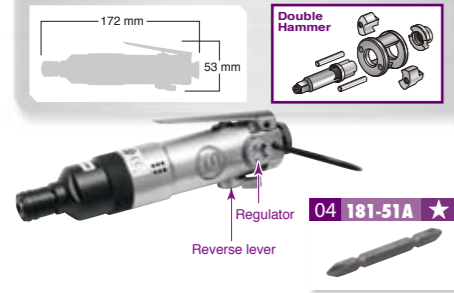

SI-1060 Impact Driver

- 6mm capacity straight grip impact driver
- Compact, lightweight, ergonomic design for easy operation
- General use

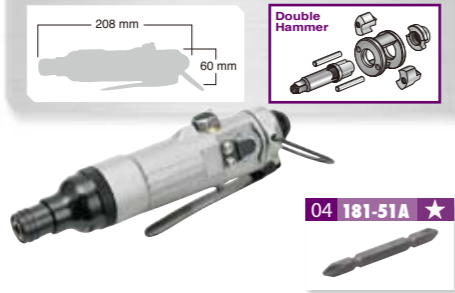

SI-1062 Impact Driver

- More powerful than SI-1061
- Built-in regulator
- Compact body design for reduce weight and easy operation

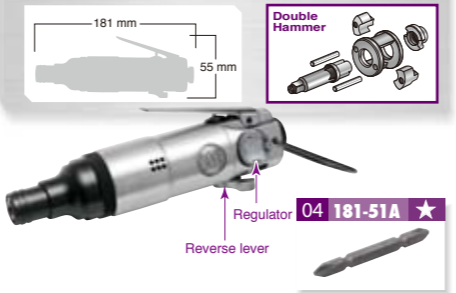

SI-1065 Impact Driver

- 6mm capacity pistol grip impact driver
- General use
- Ergonomic pistol grip for easy operation



SI-1070 Impact Driver

- 6mm capacity pistol grip impact driver
- General use
- Compact, lightweight and a "feather touch" trigger for easy operation.

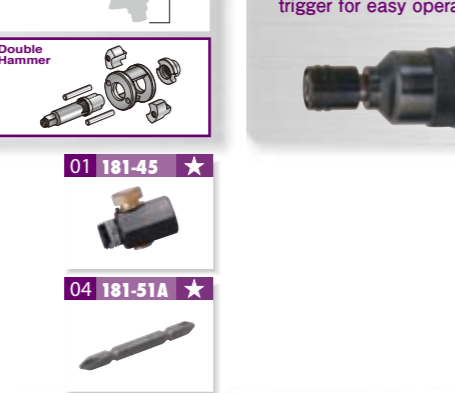

SI-1356D Impact Driver

- 8mm capacity pistol grip impact driver
- Double hammer mechanism



SI-1365D Impact Driver

- 8mm capacity pistol grip impact driver
- Industrial use



Model Number	Shank Size in./mm	Max Torque Nm/(ft-lb)	Working Torque Nm/(ft-lb)	Bolt Cap mm/(in.)	Free Speed rpm	Weight kg/(lb)	Noise Level dBA/(power)	Vibration m/s ²	Avg. Air Consumption CFM	Air Inlet Size in.	Hose Size mm/(in.)	Clutch Type
SI-1052	1/4/(6.35)	70/(51.6)	0-60/(0-44)	5/(3/16)	13,000	0.56/(1.23)	91/(104)	4.1	2.3	1/4	10/(3/8)	Double Hammer
SI-1060	1/4/(6.35)	65/(47.9)	0-50/(0-37)	6/(1/4)	11,000	0.87/(1.92)	92/(104)	4.0	2.9	1/4	10/(3/8)	Double Hammer
SI-1062	1/4/(6.35)	95/(70.1)	0-70/(0-52)	6/(1/4)	11,000	0.79/(1.74)	91/(104)	4.0	2.8	1/4	10/(3/8)	Double Hammer
SI-1065	1/4/(6.35)	65/(47.9)	0-45/(0-33)	6/(1/4)	11,000	0.98/(2.16)	94/(107)	5.0	3.4	1/4	10/(3/8)	Double Hammer
SI-1070	1/4/(6.35)	35/(25.8)	0-30/(0-22)	6/(1/4)	11,000	0.65/(1.43)	82/(95)	< 2.5	2.1	1/4	10/(3/8)	Double Hammer
SI-1356D	1/4/(6.35)	55/(40.6)	0-45/(0-33)	8/(5/16)	9,000	1.22/(2.69)	89/(102)	3.3	2.7	1/4	10/(3/8)	Double Hammer
SI-1365D	1/4/(6.35)	70/(51.6)	0-60/(0-44)	8/(5/16)	8,000	1.32/(2.92)	83/(96)	3.3	3.3	1/4	10/(3/8)	Double Hammer

SCREW DRIVERS

★ : Attachment Included
☆ : Accessories

SI-1140 Screw Driver

- 4mm capacity straight grip screw driver
- Clutch mechanism for easy adjustment of maximum torque



SI-1161 Screw Driver

- 6mm capacity straight grip screw driver
- Adjustable clutch
- Compact, lightweight, and ergonomic design for easy operation



SI-1166A Screw Driver

- 6mm capacity pistol grip screw driver
- Adjustable clutch
- Ergonomic pistol grip for easy operation



SI-1166-8A Screw Driver

- 8mm capacity pistol grip screw driver
- Adjustable clutch
- Ergonomic pistol grip for easy operation



SI-1170 Screw Driver

- An adjustment ring with easy torque adjustment
- The full composite tool of an original design
- An oscillation is eased by a soft grip



Model Number	Shank Size in./mm	Max Torque Nm/(ft-lb)	Working Torque Nm/(ft-lb)	Bolt Cap mm/(in.)	Free Speed rpm	Weight kg/(lb)	Noise Level dBA/(power)	Vibration m/s ²	Avg. Air Consumption CFM	Air Inlet Size in.	Hose Size mm/(in.)	Clutch Type
SI-1140	1/4/(6.35)	1.5/(1.1)	0.3-1.5/(0.2-1.1)	4/(5/32)	1,700	0.62/(1.36)	84/(96)	4.5	1.9	1/4	10/(3/8)	Cushion Type
SI-1161	1/4/(6.35)	5.0/(3.7)	1.5-5.0/(1.1-3.7)	6/(1/4)	1,600	1.12/(2.46)	91/(104)	< 2.5	2.8	1/4	10/(3/8)	Cushion Type
SI-1166A	1/4/(6.35)	5.0/(3.7)	1.5-5.0/(1.1-3.7)	6/(1/4)	2,000	1.18/(2.60)	94/(107)	< 2.5	3.5	1/4	10/(3/8)	Cushion Type
SI-1166-8A	1/4/(6.35)	9.0/(6.6)	1.5-9.0/(1.1-6.6)	8/(5/16)	800	1.35/(2.97)	95/(108)	< 2.5	3.3	1/4	10/(3/8)	Cushion Type
SI-1170	1/4/(6.35)	20/(14.8)	4-11/(2.9-8.1)	8/(5/16)	550	0.85/(1.87)	83/(96)	4.0	2.3	1/4	10/(3/8)	Cushion Type

DRIVER ACCESSORIES



IMPACT WRENCHES
DRIVERS
RATCHET WRENCHES
SANDERS
POLISHER
GRINDERS
SPOTMILLS
CUTTING TOOLS
OTHERS
MAINTENANCE CHECK
QUALITY
ACCESSORIES

RATCHET WRENCHES

RATCHET WRENCHES / 1/4" RATCHET WRENCHES • 3/8" RATCHET WRENCHES

SI-1107B 1/4" Ratchet Wrench

- Maximum Torque:30Nm
- Super small ratchet wrench with 1/4"sq. anvil
- Smaller than SI-1200B & SI-1205B

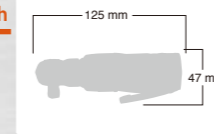

SI-1200B 1/4" Ratchet Wrench

- Maximum Torque:35Nm
- Light and small ratchet wrench with 1/4"sq. anvil
- This model is the "Mini Ratchet Wrench" standard in the air tools industry

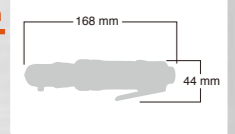

SI-1207 1/4" Ratchet Wrench

- Maximum Torque:38Nm
- Same body size as SI-1200B but with a plastic body cover that protects your hand from the cold
- 360° air inlet swivel

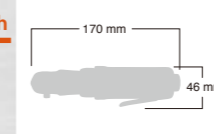

SI-1251 1/4" Ratchet Wrench

- Maximum Torque:45Nm
- Japan and foreign patent(s) pending as the "Slide Switch" for the reverse function
- Plastic covered small size body
- 1/4"sq. anvil

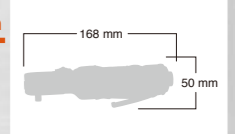

SI-1108B 3/8" Ratchet Wrench

- Maximum Torque:30Nm
- Super small ratchet wrench with 3/8"sq. anvil
- Smaller than SI-1200B & SI-1205B

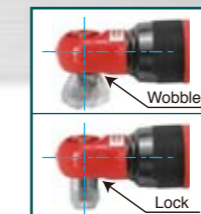
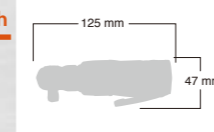

SI-1205B 3/8" Ratchet Wrench

- Maximum Torque:40Nm
- Light and small ratchet wrench with 3/8"sq. anvil
- This model is the "Mini Ratchet Wrench" standard in the air tools industry

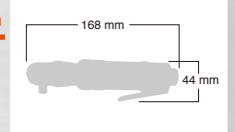

Model Number	Shank Size in./mm	Maximum Torque Nm/ft-lb	Working Torque Range Nm/ft-lb	Bolt Cap mm/in.	Free Speed rpm	Weight kg/lb	Over Length mm/in.	Noise Level dBA/power	Vibration m/s ²	Avg. Air Consumption CFM	Air Inlet Size in.	Hose Size mm/in.
SI-1107B	1/4 / (6.35)	30/(22)	0-25/(0-18)	6.35/(1/4)	300	0.39/(0.86)	125/(4.92)	78/(91)	< 2.5	1.8	1/8	10/(3/8)
SI-1200B	1/4 / (6.35)	35/(26)	0-30/(0-22)	6.35/(1/4)	200	0.51/(1.11)	168/(6.61)	85/(97)	3.5	1.6	1/4	10/(3/8)
SI-1207	1/4 / (6.35)	38/(28)	0-30/(0-22)	6.35/(1/4)	200	0.54/(1.18)	170/(6.69)	85/(97)	3.5	1.6	1/4	10/(3/8)
SI-1251	1/4 / (6.35)	45/(33)	0-33/(0-24)	6.35/(1/4)	200	0.56/(1.24)	168/(6.61)	79/(92)	3.5	2.4	1/4	10/(3/8)
SI-1108B	3/8 / (9.5)	30/(22)	0-25/(0-18)	10/(3/8)	300	0.40/(0.88)	125/(4.92)	78/(91)	< 2.5	1.8	1/8	10/(3/8)
S-1205B	3/8 / (9.5)	40/(30)	0-30/(0-22)	10/(3/8)	220	0.51/(1.12)	168/(6.61)	86/(98)	3.5	1.6	1/4	10/(3/8)

SI-1208 3/8" Ratchet Wrench

- Maximum Torque:40Nm
- Same body size as SI-1205B but with a plastic body cover that protects your hand from the cold
- Also helps to absorb vibrations for reduced operator fatigue Built-in air
- Regulator for easy adjustment of torque

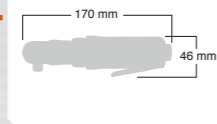

SI-1252 3/8" Ratchet Wrench

- Maximum Torque:47Nm
- Japan and foreign patent(s) pending as the "Slide Switch" for the reverse function
- Plastic covered small size body
- 3/8"sq. anvil

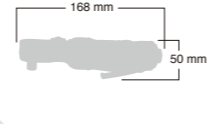

SI-1261/1261S 3/8" Ratchet Wrench

- Maximum Torque:110Nm
- Japan and foreign patent(s) pending as the "Slide Switch" for the reverse function
- Plastic covered regular size body
- The lightest 960g in this class
- Lightweight and high strength super duralumin is used for housing

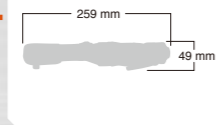

SI-1261

SI-1261S

SI-1320A 3/8" Ratchet Wrench

- Maximum Torque:80Nm
- Standard ratchet wrench with the front exhaust
- 3/8"sq. anvil
- Reasonable price

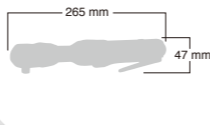

SI-1340B 3/8" Ratchet Wrench

- Maximum Torque:110Nm
- Premium quality ratchet wrench with a rear exhaust and plastic body cover
- Low noise levels and precise planetary gear mechanism assures the highest power transfer, durability and reducing vibration
- 360° air inlet swivel directs air away from operator and workplace

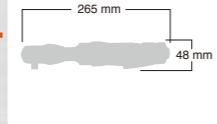

SI-1252		168mm
SI-1208		170mm
SI-1241A		190mm
SI-1288		211mm
SI-1261/1261S		259mm
SI-1262/1262S		259mm
SI-1345B		263mm
SI-1320A		265mm
SI-1325A		265mm
SI-1340B		265mm
SI-1435		368mm

SI-1241A 3/8" Ratchet Wrench

- Swivel head with 9 levels
- An activity is possible at the locations which cannot work in the usual spanner and/or ratchet wrenches.
- The socket lock mechanism does not drop a socket on a narrow place.
- Japan and Foreign patent(s) pending as the "Quick release function" for easily releasing sockets

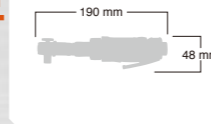

Swivel head



Quick release

SI-1262/1262S 1/2" Ratchet Wrench

- Maximum Torque:115Nm
- Japan and foreign patent(s) pending as the "Slide Switch" for the reverse function
- Plastic covered regular size body
- The lightest 970g in this class we have ever had
- Lightweight and high strength super duralumin is used for housing

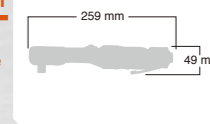

SI-1262

SI-1262S

SI-1325A 1/2" Ratchet Wrench

- Maximum Torque:90Nm
- Standard ratchet wrench with the front exhaust
- 1/2"sq. anvil
- Best selling model in the world at a reasonable price

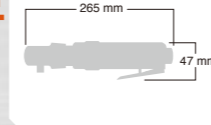

SI-1345B 1/2" Ratchet Wrench

- Maximum Torque:115Nm
- Premium quality ratchet wrench with a rear exhaust and plastic body cover
- Low noise levels and precise planetary gear mechanism
- Swivel exhaust muffler directs air away from operator and workplace
- Built-in air regulator for easy adjustment of torque
- 360° air inlet swivel

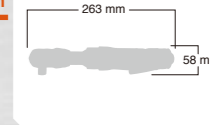

SI-1435 1/2" Ratchet Wrench

- Maximum Torque:160Nm
- The largest ratchet wrench in the range with the highest torque
- 1/2"sq. anvil
- Good for running nuts on tractor blades

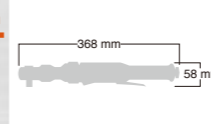

SI-1288 HEX 17mm Through

- Maximum Torque:45Nm
- Ratchet wrench with the unique inner sockets 8mm, 10mm, 11mm, 12mm and 13mm of the sockets are available
- Specially designed for using in small space

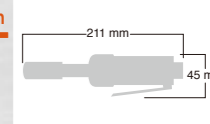

Inner Sockets



Model Number	Shank Size in./mm	Maximum Torque Nm/(ft-lb)	Working Torque Range Nm/(ft-lb)	Bolt Cap mm/(in.)	Free Speed rpm	Weight kg/(lb)	Over Length mm/(in.)	Noise Level dBA/(power)	Vibration m/s ²	Avg. Air Consumption CFM	Air Inlet Size in.	Hose Size mm/(in.)
SI-1208	3/8 / (9.5)	40/(30)	0-30/(0-22)	10/(3/8)	200	0.54/(1.20)	170/(6.69)	86/(99)	3.5	2.2	1/4	10/(3/8)
SI-1252	3/8 / (9.5)	47/(35)	0-35/(0-26)	10/(3/8)	260	0.56/(1.24)	168/(6.61)	79/(92)	3.5	2.4	1/4	10/(3/8)
SI-1261/ SI-1261S	3/8 / (9.5)	110/(81)	0-65/(0-48)	10/(3/8)	170	1.20/(2.65)/ 0.96/(2.12)	259/(10.2)	84/(97)	7.0	3.0	1/4	10/(3/8)
SI-1320A	3/8 / (9.5)	80/(59)	0-60/(0-44)	12/(1/2)	160	1.16/(2.57)	265/(10.4)	93/(105)	7.6	2.7	1/4	10/(3/8)
SI-1340B	3/8 / (9.5)	110/(81)	0-85/(0-63)	12/(1/2)	160	1.14/(2.50)	265/(10.4)	89/(102)	7.6	2.5	1/4	10/(3/8)

Model Number	Shank Size in./mm	Maximum Torque Nm/(ft-lb)	Working Torque Range Nm/(ft-lb)	Bolt Cap mm/(in.)	Free Speed rpm	Weight kg/(lb)	Over Length mm/(in.)	Noise Level dBA/(power)	Vibration m/s ²	Avg. Air Consumption CFM	Air Inlet Size in.	Hose Size mm/(in.)
SI-1241A	3/8 / (9.5)	30/(22.1)	0-25/(0-18.4)	10/(3/8)	250	0.63/(1.38)	190/(7.48)	89/(101)	7.6	1.9	1/4	10/(3/8)
SI-1262/ SI-1262S	1/2 / (12.7)	115/(85)	0-70/(0-52)	14/(9/16)	170	1.21/(2.67)/ 0.97/(2.14)	259/(10.2)	84/(97)	7.0	3.0	1/4	10/(3/8)
SI-1325A	1/2 / (12.7)	90/(66)	0-70/(0-52)	14/(9/16)	160	1.17/(2.58)	265/(10.4)	92/(105)	8.6	2.5	1/4	10/(3/8)
SI-1345B	1/2 / (12.7)	115/(85)	0-90/(0-66)	14/(9/16)	160	1.15/(2.53)	263/(10.4)	89/(102)	7.6	2.5	1/4	10/(3/8)
SI-1435	1/2 / (12.7)	160/(118)	0-110/(0-81)	16/(5/8)	140	1.95/(4.31)	368/(14.5)	97/(110)	9.7	4.7	1/4	10/(3/8)
SI-1288	HEX 17mm	45/(33)	0-35/(0-26)	8-17/(5/16-11/16)	180	0.54/(1.20)	211/(8.31)	86/(99)	6.3	1.9	1/4	10/(3/8)

SANDERS

SANDERS / BELT SANDERS

★ : Attachment Included
☆ : Accessories

SI-2700

Belt Sander

- 10mm sanding belt sander
- Quick and easy belt change
- Adjustable arm angle

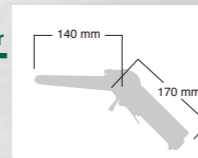

45 181-45 ☆



Attachment included ★



10mm Sanding belt #60x6

Attachment included
10mm Sanding belt #60x6

Accessories
10mm Sanding belt #40
10mm Sanding belt #60
10mm Sanding belt #80
10mm Sanding belt #100
10mm Sanding belt #120

SI-2700L/2700LS

Belt Sander

Head rotates 120 degrees for operating convenience. Variable speed throttle for positive control.

- Best for the light grinding, sanding and deburring.

- SI-2700L
- SI-2700LS
- For nugget grinding of spot welding

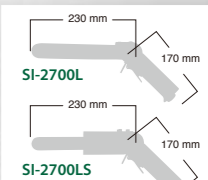

45 181-45 ☆



Attachment included ★



Attachment included
10mm Felt belt #60 x 1
10mm Felt belt #150 x 1
10mm Felt belt #320 x 1

45 181-45 ☆



Attachment included ★



Attachment included
13mm Sanding belt #60 x 5

SI-2800

Belt Sander

- 20mm sanding belt sander
- Safety cover over belt wheel

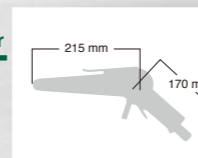

45 181-45 ☆



Attachment included ★



20mm Sanding belt #60x6

Attachment included
20mm Sanding belt #60x6

Accessories
20mm Sanding belt #40
20mm Sanding belt #60
20mm Sanding belt #80
20mm Sanding belt #100
20mm Sanding belt #120

SI-2830

Belt Sander

- 30mm sanding belt sander
- Safety cover over belt wheel
- Side handle for firm tool control

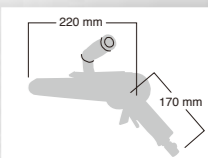

45 181-45 ☆



Attachment included ★



30mm Sanding belt #60x6

Attachment included
30mm Sanding belt #60x6

Accessories
30mm Sanding belt #40
30mm Sanding belt #60
30mm Sanding belt #80
30mm Sanding belt #100
30mm Sanding belt #120

Model Number	Belt Size mm(in.)	Free Speed rpm	Out Put Watt	Weight kg/(lb)	Noise Level dBA/(power)	Vibration m/s ²	Avg. Air Consumption CFM	Air Inlet Size in.	Hose Size mm/(in.)
SI-2700	10x330	15,000	317	0.82/(1.82)	90/(102)	< 2.5	3.3	1/4	10/(3/8)
SI-2700L/2700LS	10x460/13x460	15,000	317	0.85/(1.87) 0.9/(1.98)	90/(102)	< 2.5	3.3	1/4	10/(3/8)
SI-2800	20x520	15,000	429	1.43/(3.14)	90/(103)	< 2.5	3.8	1/4	10/(3/8)
SI-2830	30x540	10,000	582	2.02/(4.45)	93/(106)	< 2.5	5.3	1/4	10/(3/8)

BELT SANDER ACCESSORIES

10mm Sanding belt



20mm Sanding belt



30mm Sanding belt





IMPACT WRENCHES
DRIVERS
RATCHET WRENCHES
SANDERS
POLISHER
GRINDERS
DRILLS/SPOTMILLS
CUTTING TOOLS
OTHERS
MAINTENANCE CHECK
QUALITY
ACCESSORIES

SI-3100 Dual Action Sander

SI-3100M

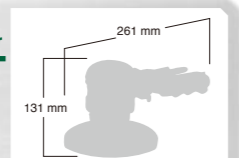
- Multi purpose dual action sander with bar grip
- 7mm orbit diameter for rough sanding
- The best and longest selling 6" random orbit model at a reasonable price





07 486-3

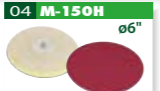

☆ SI-3100 / ☆ SI-3100M

04 M-150H



☆ SI-3100 / ☆ SI-3100M

SI-3103A Dual Action Sander

SI-3103AM : Velcro pad model

- Standard dual action sander with palm grip
- 5" pad are available
- Powerful, high quality air motor
- 5mm orbit diameter Suitable for both rough and finish sanding





02 ME-125H



☆ SI-3103A / ☆ SI-3103AM

03 PE-125H



☆ SI-3103A / ☆ SI-3103AM

SI-3113A Dust Free Dual Action Sander

SI-3113AM : Velcro pad model

- Dust free dual action sander with 5" leather pad model
- The self generating dust system helps create a clean working environment, protecting the operator from harmful paint and filler particles
- Light weight and compact palm grip body





09 ME-125HD



☆ SI-3113A / ☆ SI-3113AM

10 PE-125HD



☆ SI-3113A / ☆ SI-3113AM

SI-3101 Dual Action Sander

SI-3101M : Velcro pad model

- Light weight and compact palm grip body makes smooth and easy operation with 5" leather pad model
- 5" velcro pad also available 5mm orbit diameter for finish sanding
- Ergonomic, compact and lightweight design for easy operation





02 ME-125H



☆ SI-3101 / ☆ SI-3101M

03 PE-125H



☆ SI-3101 / ☆ SI-3101M

SI-3111 Dust Free Dual Action Sander

SI-3111M : Velcro pad model

- Dust free dual action sander
- The self generating dust system helps create a clean working environment, protecting the operator from harmful paint and filler particles
- Light weight and compact palm grip body
- 5" leather pad





09 ME-125HD



☆ SI-3111 / ☆ SI-3111M

10 PE-125HD



☆ SI-3111 / ☆ SI-3111M

SI-3103-6A Dual Action Sander

SI-3103-6AM : Velcro pad model

- The same quality features of SI-3103 with 6" pad model





04 M-150H



☆ SI-3103-6A / ☆ SI-3103-6AM

05 P-150H



☆ SI-3103-6A / ☆ SI-3103-6AM

SI-3113-6A Dust Free Dual Action Sander

SI-3113-6AM : Velcro pad model

- The same quality features of SI-3113 with 9 holes 6" leather pad model





11 M-150HD 6



☆ SI-3113-6A / ☆ SI-3113-6AM

12 P-150HD 6



☆ SI-3113-6A / ☆ SI-3113-6AM

SI-3101-6 Dual Action Sander

SI-3101-6M : Velcro pad model

- The same quality features of SI-3101 with 6" leather pad model





04 M-150H



☆ SI-3101-6 / ☆ SI-3101-6M

05 P-150H





☆ SI-3101-6 / ☆ SI-3101-6M

SI-3111-6 Dust Free Dual Action Sander

SI-3111-6M : Velcro pad model

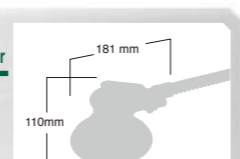
- The same quality features of SI-3111 with 9 holes 6" leather pad model





11 M-150HD 6



☆ SI-3111-6 / ☆ SI-3111-6M

12 P-150HD 6



☆ SI-3111-6 / ☆ SI-3111-6M

SI-3105A Dual Action Sander

SI-3105AM : Velcro pad model

- Premium quality dual action sander with bar grip
- Low vibration
- Suitable for both of light work and continuous work





02 ME-125H



☆ SI-3105A / ☆ SI-3105AM

03 PE-125H



☆ SI-3105A / ☆ SI-3105AM

45 181-45 ☆



SI-3105-6A Dual Action Sander

SI-3105-6AM : Velcro pad model

- The same quality features of SI-3105 with 6" pad model





04 M-150H



☆ SI-3105-6A / ☆ SI-3105-6AM

05 P-150H



☆ SI-3105-6A / ☆ SI-3105-6AM

45 181-45 ☆



Model Number	Pad/Disc Size mm/(in.)	Spindle Size Female	Orbit Dia mm	Free Speed rpm	Out Put Watt	Weight kg/(lb)	Noise Level dBA/(power)	Vibration m/s ²	Avg. Air Consumption CFM	Air Inlet Size in.	Hose Size mm/(in.)
SI-3100/3100M	150/(6")	5/16-24UNF	7	8,000	542	1.82/(4.01)	80/(93)	4.2	2.3	1/4	10/(3/8)
SI-3101/3101M	125/(5")	5/16-24UNF	5	10,000	148	0.92/(2.03)	73/(86)	< 2.5	2.2	1/4	10/(3/8)
SI-3111/3111M	125/(5")	5/16-24UNF	5	9,500	148	1.27/(2.81)	88/(101)	< 2.5	2.3	1/4	10/(3/8)
SI-3101-6/3101-6M	150/(6")	5/16-24UNF	5	10,000	148	0.94/(2.07)	73/(86)	< 2.5	2.2	1/4	10/(3/8)
SI-3111-6/3111-6M	150/(6")	5/16-24UNF	5	9,500	148	1.29/(2.84)	88/(101)	< 2.5	2.3	1/4	10/(3/8)

Model Number	Pad/Disc Size mm/(in.)	Spindle Size Female	Orbit Dia (mm)	Free Speed rpm	Out Put Watt	Weight kg/(lb)	Noise Level dBA/(power)	Vibration m/s ²	Avg. Air Consumption CFM	Air Inlet Size in.	Hose Size mm/(in.)
SI-3103A/3103AM	125/(5")	5/16-24UNF	5	8,200	134	1.18/(2.60)	90/(102)	< 2.5	2.8	1/4	10/(3/8)
SI-3113A/3113AM	125/(5")	5/16-24UNF	5	8,000	134	1.57/(3.46)	91/(104)	< 2.5	2.4	1/4	10/(3/8)
SI-3103-6A/3103-6AM	150/(6")	5/16-24UNF	5	8,200	134	1.20/(2.64)	90/(102)	< 2.5	2.8	1/4	10/(3/8)
SI-3113-6A/3113-6AM	150/(6")	5/16-24UNF	5	8,000	134	1.59/(3.50)	91/(104)	< 2.5	2.4	1/4	10/(3/8)
SI-3105A/3105AM	125/(5")	5/16-24UNF	6	9,000	569	1.67/(3.69)	87/(99)	2.7	3.0	1/4	10/(3/8)
SI-3105-6A/3105-6AM	150/(6")	5/16-24UNF	6	9,000	569	1.68/(3.71)	87/(99)	2.7	3.0	1/4	10/(3/8)

IMPACT WRENCHES
DRIVERS
RATCHET WRENCHES
SANDERS
POLISHER
GRINDERS
DRILLS/SPOTMILLS
CUTTING TOOLS
OTHERS
MAINTENANCE CHECK
QUALITY ACCESSORIES

SI-3118 Dust Free Dual Action Sander

SI-3118M : Velcro pad model

- Dust free dual action sander with 5" leather pad model
- The self generating suction system makes for a clean working environment
- Bar grip body
- Dust free operation protects the operator from the harmful particles of paint and filler

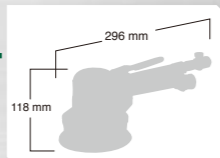

SI-3118-6 Dust Free Dual Action Sander

SI-3118-6M : Velcro pad model

- The same quality features of SI-3118 with 9 holes 6" leather pad model

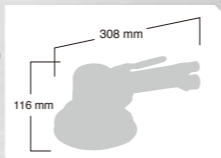

SI-3005 Orbital Sander

- Bar grip orbital sander
- Paper size : 100mm x 180mm
- The tool has paper clips and you can use roll paper abrasive of 100mm width

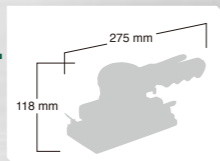

SI-3007 Orbital Sander

SI-3007M : Velcro pad model

- Paper size : 100mm x 180mm
- The tool has paper clips and you can use roll paper abrasive of 100mm width
- One hand grip for easy operation

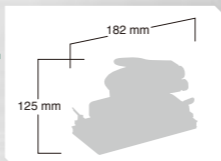

SI-3115R Dust Free Geared Dual Action Sander

- Geared sander with 5" Velcro pad.
- 1,000rpm low speed and high torque
- Amazing power is generated with the gear mechanism
- For heavy sanding work

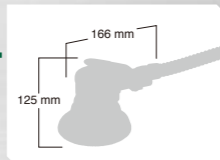

SI-3115R-6 Dust Free Geared Dual Action Sander

- The same quality features of SI-3115 with 6" velcro pad model

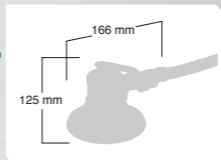

SI-3001A Orbital Sander

SI-3001AM : Velcro pad model

- Light weight and compact palm grip orbital sander
- Paper size : 75mm x 110mm

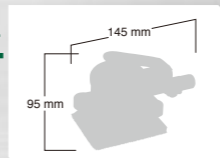

SI-3011A Dust Free Orbital Sander

SI-3011AM : Velcro pad model

- Dust free orbital sander with palm grip and leather pad
- Light weight and compact body
- Paper size : 75mm x 110mm
- Self generated suction system protects operator from harmful particles of paint and filler

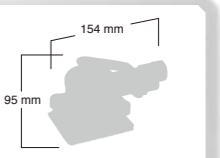

SI-3003A Orbital Sander

SI-3003AM : Velcro pad model

- Palm grip orbital sander
- Paper size : 75mm x 110mm
- Powerful high quality air motor. 5mm orbit diameter

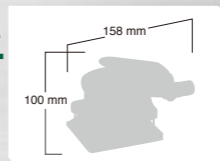

SI-3013A Dust Free Orbital Sander

SI-3013AM : Velcro pad model

- Dust free orbital sander with palm grip and leather pad model
- Paper size : 75mm x 110mm
- Self generated suction system protects operator from harmful particles of paint and filler

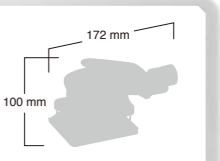

T.P.S Triple Pillar Stud System

- Structure which the 3 pillars by a special plastic.
- It has few losses of power compared with old rubber.
- Thereby, it is excellent in durability, long life and grinding power.

SI-3018A Dust Free Orbital Sander

SI-3018AM : Velcro pad model

- Dust free orbital sander with bar grip
- Paper size : 100mm x 180mm
- With leather pad

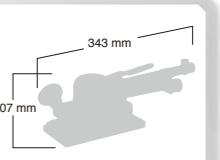

Model Number	Pad/Disc Size mm/(in.)	Spindle Size Female	Orbit Dia mm	Free Speed rpm	Out Put Watt	Weight kg/(lb)	Noise Level dBA/(power)	Vibration m/s ²	Avg. Air Consumption CFM	Air Inlet Size in.	Hose Size mm/(in.)
SI-3118/3118M	125/(5")	5/16-24UNF	6	8,000	569	2.11/(4.65)	88/(100)	< 2.5	2.9	1/4	10/(3/8)
SI-3118-6/3118-6M	150/(6")	5/16-24UNF	6	9,500	569	2.15/(4.74)	88/(100)	< 2.5	2.9	1/4	10/(3/8)
SI-3005	90x165	—	4.8	8,000	289	1.87/(4.13)	92/(104)	< 2.5	2.3	1/4	10/(3/8)
SI-3007/3007M	95x175	—	4.8	7,500	275	1.82/(4.00)	89/(102)	< 2.5	2.8	1/4	10/(3/8)
SI-3115R	125/(5")	—	4.4	1,000	148	1.49/(3.27)	88/(100)	< 2.5	2.3	1/4	10/(3/8)
SI-3115R-6	150/(6")	—	4.4	1,000	148	1.51/(3.33)	88/(100)	< 2.5	2.3	1/4	10/(3/8)

Model Number	Pad/Disc Size mm/(in.)	Orbit Dia mm	Free Speed rpm	Out Put Watt	Weight kg/(lb)	Noise Level dBA/(power)	Vibration m/s ²	Avg. Air Consumption CFM	Air Inlet Size in.	Hose Size mm/(in.)
SI-3001A/3001AM	75x100	4	9,000	148	0.80/(1.77)	74/(86)	< 2.5	2.3	1/4	10/(3/8)
SI-3011A/3011AM	75x100	4	9,000	148	1.15/(2.53)	86/(99)	< 2.5	2.5	1/4	10/(3/8)
SI-3003A/3003AM	75x100	4	8,000	134	1.05/(2.31)	90/(102)	< 2.5	2.8	1/4	10/(3/8)
SI-3013A/3013AM	75x100	4	7,000	134	1.46/(3.22)	87/(100)	< 2.5	2.3	1/4	10/(3/8)
SI-3018A/3018AM	95x175	4.8	7,000	222	2.31/(5.09)	87/(100)	< 2.5	3.1	1/4	10/(3/8)

IMPACT WRENCHES
DRIVERS
RATCHET WRENCHES
SANDERS
POLISHER
GRINDERS
DRILLS/SPOTMILLS
CUTTING TOOLS
OTHERS
MAINTENANCE CHECK
QUALITY ACCESSORIES

SI-3102M Mini Dual Action Sander

- Compact body design for reduce weight and easy operation
- New design for 3" pad size Mini Sander

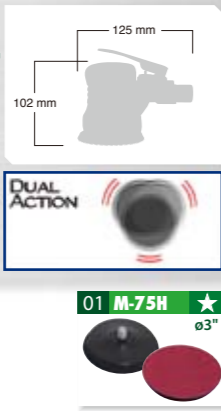

01 M-75H ☆
 ø3"



SI-3112M Mini Dust Free Dual Action Sander

- Compact body design for reduce weight and easy operation with
- The self generating dust system helps create a clean working
- New design for Mini Sander with 3"pad

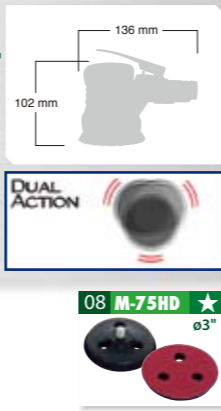

08 M-75HD ☆
 ø3"



SI-2007A Mini Sander

- Angle head sander with 2" disc. Light and compact. It is useful for sanding and polishing work at the narrow place

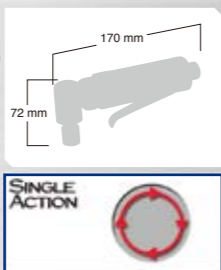

28 MESP-65 ☆
 ø65mm

29 262-21MD ☆
 ø48mm

30 SHP-50M ☆
 ø50mm

32 M-20x60/B ☆
 ø60mm

33 M-60 ☆
 ø60mm

SI-2008 Heavy Duty Mini Sander

- High durability of SI-2007A is a model for heavy duty

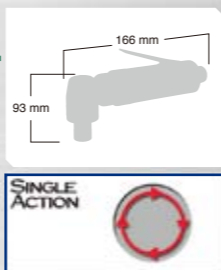

28 MESP-65 ☆
 ø65mm

29 262-21MD ☆
 ø48mm

30 SHP-50M ☆
 ø50mm

32 M-20x60/B ☆
 ø60mm

33 M-60 ☆
 ø60mm

SI-2107A Mini Sander

- Angle head dual action sander with 2" Velcro pad
- You can use 2" sanding paper, wool buff or sponge buff
- A good tool for sanding and polishing where space is limited
- High quality gears provide long tool life
- Dual action for easy operation and a good finish



29 262-21MD ☆
 ø48mm

30 SHP-50M ☆
 ø50mm

32 M-20x60/B ☆
 ø60mm

33 M-60 ☆
 ø60mm

SI-2108 Heavy Duty Mini Sander

- High durability of SI-2107A is a model for heavy duty

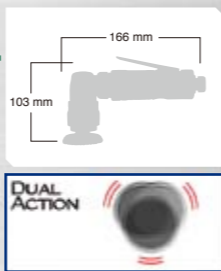

31 114DA-12 ☆
 ø70mm

34 119-101 ☆
 ø80mm

35 119-102 ☆
 ø80mm

SI-2110 Mini Dual Action Sander

- Engineered for the most aggressive sanding applications
- Durable ball-bearing construction ensures, a smooth power delivery

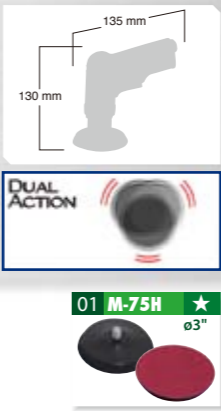

01 M-75H ☆
 ø3"



SI-2202 Disc Sander

- Ideal for the removal of rust, surface deposits, and welds in hard -to-reach areas
- Doble-sided, adjustable speed settings provide variability for a broader range of applications
- Designed for direct mounting of the 3M Roloc Pad

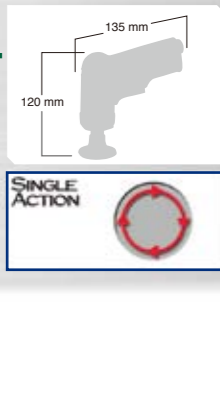

SI-2201 Disc Sander

- Designed for direct mounting of the 3M Roloc Pad
- No adaptors necessary
- Option : 2" and 3"pads are available

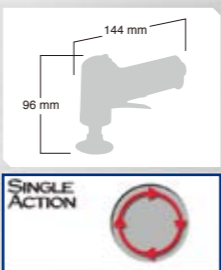

SI-2210 Disc Sander

- A long seller in the market. Very popular high speed 4" disc sander
- Easy one hand operation
- Disc inside dia.

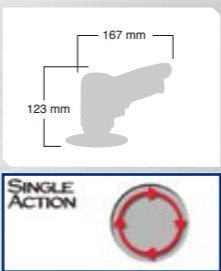

36 170C-27 ☆
 ø3"

37 170C-30 ☆
 ø4"

SI-2300 Disc Sander

- Vertical grip for stable and easy operation sander with 7" disc

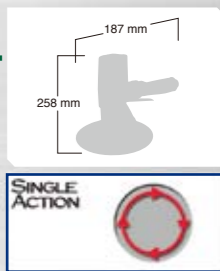



38 820-52 ☆
 ø7"

Model Number	Pad/Disc Size mm/(in.)	Spindle Size Female	Orbit Dia mm	Free Speed rpm	Out Put Watt	Weight kg/(lb)	Noise Level dBA/(power)	Vibration m/s ²	Avg. Air Consumption CFM	Air Inlet Size in.	Hose Size mm/(in.)
SI-3102M	75/(3")	5/16-24UNF	3	12,000	153	0.54/(1.19)	76/(88)	< 2.5	2.5	1/4	10/(3/8)
SI-3112M	75/(3")	5/16-24UNF	3	12,000	153	0.89/(1.96)	76/(88)	< 2.5	2.5	1/4	10/(3/8)
SI-2007A	48/(2")	M6×1	—	13,000	127	0.48/(1.07)	88/(101)	< 2.5	2.3	1/4	10/(3/8)
SI-2008	48/(2")	M6×1	—	13,000	175	0.57/(1.26)	88/(101)	< 2.5	2.8	1/4	10/(3/8)
SI-2107A	48/(2")	M6×1	3	12,500	127	0.55/(1.20)	88/(101)	< 2.5	2.3	1/4	10/(3/8)
SI-2108	48/(2")	M6×1	3	12,500	175	0.62/(1.36)	88/(101)	< 2.5	2.4	1/4	10/(3/8)

Model Number	Pad/Disc Size mm/(in.)	Spindle Size Female	Orbit Dia mm	Free Speed rpm	Out Put Watt	Weight kg/(lb)	Noise Level dBA/(power)	Vibration m/s ²	Avg. Air Consumption CFM	Air Inlet Size in.	Hose Size mm/(in.)
SI-2110	75/(3")	5/16-24UNC	3	14,000	168	0.52	84/(97)	< 2.5	2.5	1/4	10
SI-2202	75/(3")	1/4-20UNC	—	14,000	168	0.46	84/(97)	< 2.5	2.5	1/4	10
SI-2201	75/(3")	1/4-20UNC	—	17,000	174	0.50/(1.10)	84/(97)	< 2.5	2.5	1/4	10/(3/8)
SI-2210	75/(3")	7/16-20UNF	—	18,000	475	0.99/(2.17)	96/(109)	< 2.5	3.9	1/4	10/(3/8)
SI-2300	180/(7")	5/8-11UNC	—	4,000	409	2.27/(5.01)	87/(99)	< 2.5	3.9	1/4	10/(3/8)

SI-2026 Disc Sander

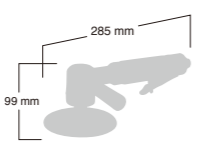
- Angle head disc sander for 5" disc. For general sanding and polishing
- High quality air motor provides high power, durability and reduced vibration
- Side handle for smooth and stable sanding

39 **136-45** ★
ø5"

SI-2351 Disc Sander

- Angle head sander with 7" disc
- Side handle for smooth and stable sanding
- Rear exhaust through the handle directs air away from operator and workplace







38 **820-52** ★
ø7"

SI-3200A Oscillation Sander

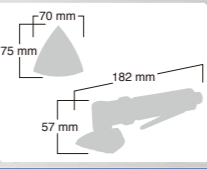
- Self suck system protects operator from harmful powder of paint and filler
- Oscillating mechanism tool with a triangular pad. For delicate and fine sanding work
- Special designed oscillation sander for narrow place and corner

40 **118-3** ★
70x75mm

SI-3300S Oscillation Sander

- Oscillating mechanism tool with 30mm diameter polishing pad
- Special design for the polishing of very small scratches, marks or dust on fresh paint of motorcar's body panel
- A specially designed oscillation sander for taking off bubble and scratch on paint surface





41 **310GS-4** ★
ø30mm

42 **310GS-5** ★
ø30mm

SI-2322WR Wet Sander

- Wet sander designed for stone sanding and polishing with water
- 3", 4" or 5" rubber Velcro pad + diamond abrasive is the best choice for the too
- Supplied with 16mm thread spindle
- Perfect waterproof mechanism ensures a long working life



Accessories side dead handle

Over head dead handle

43 **1110A-80** ★
ø80mm

SI-2322WR-E Wet Sander

- The same quality features of SI-2322 with 14mm thread spindle
- Comfortable combination lever of throttle and air regulator



Accessories side dead handle

Over head dead handle

44 **1110A-80E** ★
ø80mm

Model Number	Pad/Disc Size mm/(in.)	Spindle Size Female	Oscillating Angle	Free Speed rpm	Out Put Watt	Weight kg/(lb)	Noise Level dBA/(power)	Vibration m/s ²	Avg. Air Consumption CFM	Air Inlet Size in.	Hose Size mm/(in.)
SI-2026	125/(5")	5/8-11UNC	—	5,000	491	1.50/(3.31)	87/(100)	< 2.5	4.4	1/4	10/(3/8)
SI-2351	180/(7")	5/8-11UNC	—	4,500	458	2.13/(4.70)	85/(97)	< 2.5	4.1	1/4	10/(3/8)
SI-3200A	△75×70	M8×1.25	2.8°	★19,000	173	0.65/(1.43)	85/(98)	< 2.5	2.4	1/4	10/(3/8)
SI-3300S	ø30	M6×1	2.3°	★ 600	108	0.57/(1.25)	86/(99)	< 2.5	1.0	1/4	10/(3/8)
SI-2322WR	ø80	M16	—	5,000	435	1.30/(2.87)	78/(91)	< 2.5	4.0	1/4	10/(3/8)
SI-2322WR-E	ø80	M14	—	5,000	435	1.30/(2.87)	78/(91)	< 2.5	4.0	1/4	10/(3/8)

★ : opm (Oscillation Per Minutes)

**ROUND TYPE
(NO HOLE)**

M-75H
3" Velcro Pad
5/16-24UNF



01

ME-125H
5" Velcro Pad
5/16-24UNF



02

PE-125H
5" Leather Pad
5/16-24UNF



03

M-150H
6" Velcro Pad
5/16-24UNF



04

P-150H
6" Leather Pad
5/16-24UNF



05

257-2A
8" Leather Pad



06

486-3
6" Leather Pad
5/16-24UNF



07

**ROUND SHAPE
PAD WITH HOLES**

M-75HD
3" Velcro Pad with 3holes
5/16-24UNF



08

ME-125HD
5" Velcro Pad with 6holes
5/16-24UNF



09

PE-125HD
5" Leather Pad with 6holes
5/16-24UNF



10

M-150HD 6
6" Velcro Pad 3M Type
5/16-24UNF



11

P-150HD 6
6" Leather Pad 3M Type
5/16-24UNF



12

IMPACT WRENCHES
DRIVERS
RATCHET WRENCHES
SANDERS
POLISHER
GRINDERS
DRILLS/SPOTMILLS
CUTTING TOOLS
OTHERS
MAINTENANCE CHECK
QUALITY
ACCESSORIES

ROUND SHAPE PAD WITH HOLES

M-150HD 9
6" Velcro Pad with 9holes
5/16-24UNF

13

M-150HD 3-9
6" Velcro Pad with 9holes
5/16-24UNF

14

P-150HD 3-9
6" Leather Pad with 9holes
5/16-24UNF

15

P-150HD 9
6" Leather Pad with 9holes
5/16-24UNF

16

1140-14M
5" Velcro Pad

17

1140-59M
6" Velcro Pad

18

SQUARE TYPE (NO HOLE) & SQUARE TYPE PAD WITH HOLES

M-3003
Velcro Pad incl. Plate(490-58B) No hole
75x110

19

P-3003
Leather Pad incl. Plate(490-58B) No hole
75x110

20

M-3007
Velcro Pad incl. Plate(477-44)
100x180

21

P-3007
Leather Pad incl. Plate(477-44)
100x180

22

M-3013D
Velcro Pad incl. Plate(490-58B) with hole
75x110

23

P-3013D
Leather Pad incl. Plate(490-58B) with hole
75x110

24

475-22
Leather Pad
100x180

25

477A-5EM
Velcro Pad incl
100x180

26

477A-5EL
Leather Pad incl
100x180

27

MINI PAD & BUFF & DISC

MESP-65
φ65mm Sanding Disc

28

262-21MD
φ48mm Velcro Pad
M6

29

SHP-50M
Sanding Paper
#80

30

114DA-12
φ70mm Velcro Pad
M6

31

M-20x60/B
φ60mm Sponge Buff

32

M-60
φ60mm Wool Buff

33

119-101
φ80mm Sponge Buff
MINI BUFF

34

119-102
φ80mm Wool Buff
MINI BUFF

35

170C-27
3" Disc Pad

36

170C-30
4" Disc Pad

37

820-52
7" Back Disc

38

136-45
5" Back Disc

39

TRIANGLE TYPE & DUST CHIP ELIMINATOR PAD

118-3
Triangle Sanding Pad

40

310GS-4
φ30mm SoftPad
M6

41

310GS-5
φ30mm HardPad
M6

42

WET SANDER PAD

1110A-80
φ80mm Velcro Pad (5/8-11UNF)

43

1110A-80 E
φ80mm Velcro Pad (M14 P=2)

44

Regulator

181-45
Regulator

45

IMPACT WRENCHES
DRIVERS
RATCHET WRENCHES
SANDERS
POLISHER
GRINDERS
DRILLS/SPOTMILLS
CUTTING TOOLS
OTHERS
MAINTENANCE CHECK
ACCESSORIES
QUALITY

POLISHERS

POLISHERS / DUAL ACTION POLISHERS • SINGLE ACTION POLISHERS • GEARED DUAL ACTION POLISHERS • LIGHT SANDER POLISHERS

★ : Attachment Included
☆ : Accessories

SI-2415

Geared Dual Action Polisher

- Geared polisher with 6" Velcro pad. 1,200rpm low speed and high torque
- Designed for the wax polishing of painted motorcar body panels
- Either a wool buff or sponge buff can be used
- Geared dual action for easy operation

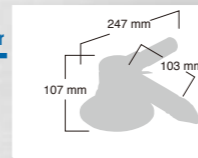

SI-3100P

Dual Action Polisher

- Dual action polisher with 6" Velcro pad
- Designed for the wax polishing of painted motorcar body panel
- Either a wool buff or sponge buff can be used
- Uniform wax work with dual action
- Professional finish without special skill

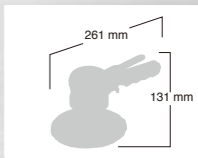

SI-2221

Single Action Polisher

- Geared polisher with 3" Velcro pad
- Light and compact body
- Either a wool buff or sponge buff can be used
- Designed for Polishing and Buffing painted surface in confined areas
- The tool most suitable for repairing small scratch or dust on painted surfaces

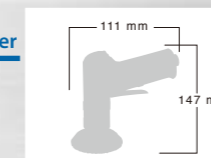

SI-2224S

Single Action Polisher

- Geared polisher with 3" Velcro pad
- Super light weight & compact design with solid composite body
- Based on two-layer molded rubber grip giving comfortable grip and reducing vibration

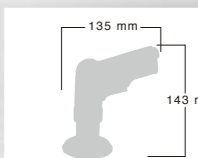

SI-2400

Single Action Polisher

- Vertical polisher with 7" back up disc
- Vertical grip for stable and easy operation

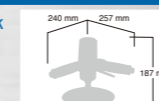

SI-2405

Light Sander Polisher

- Vertical polisher with 6" pad
- Light weight
- Precise and high quality 2 gear mechanism ensures high power transfer
- Can also be used as a sander

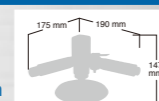

SI-2451

Single Action Polisher

- Angle head polisher with 7" back up disc
- Rear exhaust through the handle directs air away from operator and workplace

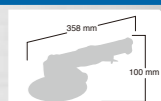

Model Number	Buff Pad Size mm/(in.)	Spindle Size Male	Spindle Size Female	Orbit Dia mm	Free Speed rpm	OutPut Watt	Weight kg/(lb)	Noise Level dBA/(power)	Vibration m/s ²	Avg.Air Consumption CFM
SI-2415	140/(6")	—	—	4.4	1,200	—	1.45	90/(103)	< 2.5	3.4
SI-3100P	150/(6")	—	5/16-24UNF	6	8,000	542	1.81/(3.99)	80/(93)	5.3	2.3
SI-2221	70/(3")	—	M6x1	—	4,500	203	0.64/(1.42)	87/(99)	< 2.5	2.5
SI-2224S	70/(3")	—	M6x1	—	5,000	270	0.60/(1.32)	85.5/(98)	< 2.5	2.5
SI-2400	180/(7")	5/8-11UNC	—	—	2,000	511	2.24/(4.94)	89/(102)	< 2.5	4.0
SI-2405	150/(6")	—	5/16-24UNF	—	1,800	241	1.17/(2.58)	83/(96)	< 2.5	2.8
SI-2451	180/(7")	5/8-11UNC	—	—	2,300	482	2.13/(4.69)	86/(99)	< 2.5	3.9

POLISERS / SINGLE ACTION POLISERS

★ : Attachment Included
☆ : Accessories

SI-2009 Single Action Polisher

- Compact body design for reduce weight
- Low Speed Single Action Sander
- New design for 3" pad size

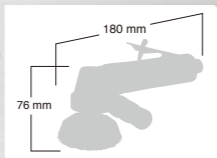

05 **M-75H** ★
ø3"

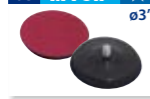

06 **119-101** ★
ø80mm



07 **119-102** ★
ø80mm

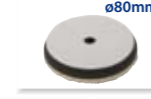

SI-2009H Single Action Polisher

- Compact body design for reduce weight
- High Speed Single Action Sander
- New design for 3" buff pad size

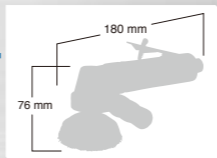

05 **M-75H** ★
ø3"

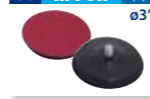

06 **119-101** ★
ø80mm



07 **119-102** ★
ø80mm

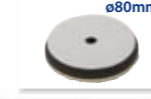

Model Number	Buff Pad Size mm/(in.)	Spindle Size Female	Free Speed rpm	OutPut Watt	Weight kg/(lb)	Noise Level dBA/(power)	Vibration m/s ²	Avg. Air Consumption CFM
SI-2009	80/(3")	5/16-24UNF	2,600	180	0.68/(1.49)	80/(93)	< 2.5	2.5
SI-2009H	80/(3")	5/16-24UNF	5,000	190	0.68/(1.50)	80/(93)	< 2.5	2.1

POLISER ACCESSORIES

M-150H

6" Velcro Pad
5/16-24UNF

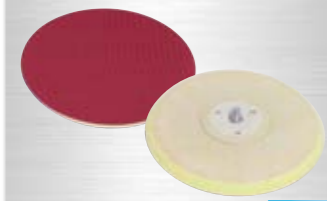

ROUND TYPE (NO HOLE) 01

114DA-12

ø3" Velcro Pad Thread
M6



ROUND TYPE MINI PAD (NO HOLE) 02

M-40x165/B

Sponge Buff



BUFF 03

M-150

Wool Buff

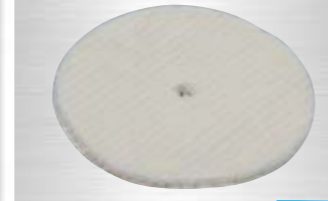

BUFF 04

M-75H

3" Velcro Pad
5/16-24UNF



05

119-101

ø80mm Sponge Buff



MINI BUFF 06

119-102

ø80mm Wool Buff



MINI BUFF 07

NVP75-240

ø75mm Sanding Paper
#120

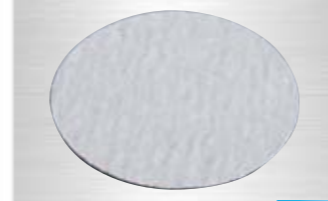

MINI BUFF 08

1145-101

ø165mm Wool Buff



BUFF 09

1145-102

ø165mm Sponge Buff

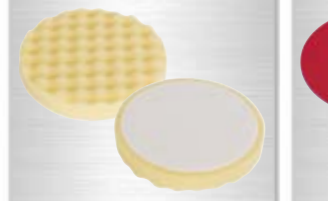

BUFF 10

1145-5

ø138mm Velcro Pad

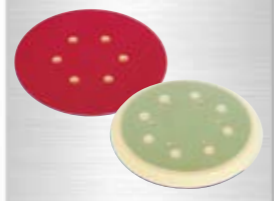

11

820-52

7" Back Disc



12

PW-3100

6" Velcro Pad
5/16-24UNF



13

GRINDERS

SI-2001S Die Grinder

SI-2001S-6 : 6mm Collet model

- Small body size die grinder
- 1/4" collet



★ **330-24** 1/4" Collet
★ **330-19** 6mm Collet
★ **330-25** 1/8" Collet
★ **330-26** 3mm Collet
★ **2001S** / ★ **2001S-6**

SI-2002 Die Grinder

SI-2002-6 : 6mm Collet model

- Compact, lightweight, ergonomic design
- Feather touch throttle lever for easy operation
- A plastic body cover absorbs tool vibrations and protects your hand from the cold
- 1/4" collet
- Built-in air regulator for easy adjustment



★ **330-24** 1/4" Collet
★ **330-19** 6mm Collet
★ **330-25** 1/8" Collet
★ **330-26** 3mm Collet
★ **2002** / ★ **2002-6**

SI-2015A Die Grinder

SI-2015A-6 : 6mm Collet model

- Planetary geared die grinder. 5,500rpm low speed and high torque
- 1/4" and 6mm collets are available
- Compact, lightweight, ergonomic design and feather touch throttle lever for easy operation
- A plastic body cover absorbs tool vibrations and protects your hand from the cold



★ **330-24** 1/4" Collet
★ **330-19** 6mm Collet
★ **330-25** 1/8" Collet
★ **330-26** 3mm Collet
★ **210-S-1A** Dead handle set
★ **2015A** / ★ **2015A-6**

SI-2006S Die Grinder

SI-2006S-6 : 6mm Collet model

- Small body size, angle head die grinder
- 1/4" collet
- Compact, lightweight, ergonomic design and feather touch throttle lever for easy operation
- Lever throttle with safety lock



★ **330-24** 1/4" Collet
★ **330-19** 6mm Collet
★ **330-25** 1/8" Collet
★ **330-26** 3mm Collet
★ **2006S** / ★ **2006S-6**

SI-2005 Die Grinder

SI-2005-6 : 6mm Collet model

- Small body size, angle head die grinder with a plastic grip cover
- 1/4" collet
- Compact, lightweight, ergonomic design and feather touch throttle lever for easy operation
- A plastic body cover absorbs tool vibrations and protects your hand from the cold
- Lever throttle with safety lock



★ **330-24** 1/4" Collet
★ **330-19** 6mm Collet
★ **330-25** 1/8" Collet
★ **330-26** 3mm Collet
★ **2005** / ★ **2005-6**

SI-2010 Die Grinder

SI-2010-6 : 6mm Collet model

- Compact, lightweight, ergonomic design and feather touch throttle lever for easy operation
- A plastic body cover absorbs tool vibrations and protects your hand from the cold



★ **330-24** 1/4" Collet
★ **330-19** 6mm Collet
★ **330-25** 1/8" Collet
★ **330-26** 3mm Collet
★ **2010** / ★ **2010-6**

SI-2011S Die Grinder

SI-2011S-6 : 6mm Collet model

- Medium body size die grinder
- 1/4" collet
- Rear exhaust directs air away from operator and work place
- Lever throttle with safety lock
- Compact, lightweight, ergonomic design and feather touch throttle lever for easy operation



★ **330-24** 1/4" Collet
★ **330-19** 6mm Collet
★ **330-25** 1/8" Collet
★ **330-26** 3mm Collet
★ **2011S** / ★ **2011S-6**

SI-2012 Die Grinder

SI-2012-6 : 6mm Collet model

- Medium body size die grinder with a plastic grip cover
- 1/4" collet
- Compact, lightweight, ergonomic design and feather touch throttle lever for easy operation
- A plastic body cover absorbs tool vibrations and protects your hand from the cold



★ **330-24** 1/4" Collet
★ **330-19** 6mm Collet
★ **330-25** 1/8" Collet
★ **330-26** 3mm Collet
★ **2012** / ★ **2012-6**

SI-2033 Cut off Grinder

- A straight grinder designed for 3" cut off discs
- For cutting sheet metal or pipe
- Especially useful for cutting the exhaust pipe on motorcars
- Compact and lightweight body with lever throttle for safety operation



★ **175-29** 3" Cut Disc

SI-2022S Die Grinder

SI-2022S-6 : 6mm Collet model

- Die grinder with the extended shaft
- 1/4" collet
- Special designed extended die grinder for unreachable place



★ **2022S** / ★ **2022S-6**
★ **2022S** / ★ **2022S-6**
★ **330-25** 1/8" Collet
★ **330-26** 3mm Collet
★ **2022S** / ★ **2022S-6**

SI-2023 Die Grinder

SI-2023-6 : 6mm Collet model

- Low Speed Die Grinder
- 1/4" collet
- Sander with the extended shaft
- Special designed extended Sander for unreachable place



★ **2023** / ★ **2023-6**
★ **2023** / ★ **2023-6**
★ **330-25** 1/8" Collet
★ **330-26** 3mm Collet
★ **2023** / ★ **2023-6**

SI-2501L/2501 Disc Grinder

- Light weight 4" disc grinder with rotary throttle
- 40% lighter than SI-2500
- Speed governor assures safety operation
- Compact and lightweight body with rotary throttle for easy operation
- Precise gear mechanism assures the highest power transfer, durability and reduced vibration



★ **240-6** 4" Disc 15mm Hole
★ **240-71** 4" Disc 16mm Hole
★ **240-6** / ★ **2501**
★ **240-71** / ★ **2501**
★ **240C-1** Disc Nut for 16mm Hole
★ **380-44** Disc Nut for 15mm Hole
★ **2501L** / ★ **2501**
★ **2501L** / ★ **2501**

SI-2500L/2500 Disc Grinder

- The high quality air motor used ensures the highest power and durability, while reducing vibration
- A trouble free tool for industry use



★ **240-6** 4" Disc 15mm Hole
★ **240-71** 4" Disc 16mm Hole
★ **240-6** / ★ **2500**
★ **240-71** / ★ **2500**
★ **240C-1** Disc Nut for 16mm Hole
★ **380-44** Disc Nut for 15mm Hole
★ **2500L** / ★ **2500**
★ **2500L** / ★ **2500**

SI-2515LA Disc Grinder

- 5" Disc grinder with safety lever throttle and 14mm thread spindle
- Speed governor assures safety operation
- Spindle lock button enable exchanging disc quickly
- Rear exhaust and lever throttle with safety lock
- Disc one push lock button model



★ **241-49** 5" Disc

SI-2505L Disc Grinder

- 5" Disc grinder with safety lever throttle
- For this model because of the safety reason
- Speed governor assures safety operation
- Lever throttle with safety lock



★ **241-49** 5" Disc

Model Number	Disc Size mm/(in.)	Collet Size	Spindle Size	Free Speed rpm (MAX)	Output Watt	Weight kg/(lb)	Noise Level dBA/(power)	Vibration m/s ²	Avg. Air Consumption CFM
SI-2001S/2001S-6	—	ø1/4" / ø6	—	25,000	173	0.37/(0.82)	85/(98)	< 2.5	2.7
SI-2002/2002-6	—	ø1/4" / ø6	—	27,000	219	0.37/(0.83)	86/(98)	< 2.5	2.6
SI-2015A/2015A-6	—	ø1/4" / ø6	—	5,500	457	0.91/(2.01)	95/(108)	< 2.5	4.2
SI-2006S/2006S-6	—	ø1/4" / ø6	—	25,000	127	0.49/(1.08)	89/(101)	3.9	2.3
SI-2005/2005-6	—	ø1/4" / ø6	—	25,000	171	0.50/(1.10)	89/(101)	< 2.5	2.4
SI-2010/2010-6	—	ø1/4" / ø6	—	25,000	247	0.52/(1.14)	88/(101)	< 2.5	1.8
SI-2011S/2011S-6	—	ø1/4" / ø6	—	25,000	422	0.60/(1.32)	93/(105)	< 2.5	4.0
SI-2012/2012-6	—	ø1/4" / ø6	—	25,000	388	0.60/(1.31)	92/(105)	< 2.5	4.0
SI-2033	75/(3")	—	ø9.5/(3/8")	20,000	347	1.00/(2.21)	93/(106)	< 2.5	4.0

Model Number	Disc Size mm/(in.)	Collet Size	Spindle Size	Free Speed rpm (MAX)	Output Watt	Weight kg/(lb)	Noise Level dBA/(power)	Vibration m/s ²	Avg. Air Consumption CFM
SI-2022S/2022S-6	—	ø1/4" / ø6	—	24,000	537	1.34/(2.94)	88/(101)	< 2.5	4.5
SI-2023/2023-6	—	ø1/4" / ø6	—	6,000	435	1.70/(3.75)	95/(107)	< 2.5	3.8
SI-2501L/2501	100/(4")	—	M10×1.5	13,000	303	1.04 / 0.91 (2.29) / (2.01)	83 / 84 (96) / (96)	5.7	2.7/2.2
SI-2500L/2500	100/(4")	—	M10×1.5	12,700	443	1.82 / 1.87 (4.02) / (4.11)	83 / 82 (96) / (94)	2.9	2.7/2.4
SI-2515LA	125/(5")	—	M14×2	12,000	651	1.65/(3.65)	84/(96)	2.9	2.8
SI-2505L	125/(5")	—	ø22/(7/8")	12,000	443	1.91/(4.22)	86/(98)	2.8	3.3

IMPACT WRENCHES
DRIVERS
RATCHET WRENCHES
SANDERS
POLISHER
GRINDERS
DRILLS/SPOTMILLS
CUTTING TOOLS
OTHERS
MAINTENANCE CHECK
QUALITY
ACCESSORIES

SI-2600L Disc Grinder

- 7" Disc grinder with safety lever throttle
- Speed governor assures safety operation
- High quality air motor assures high power, durability, reducing vibration and trouble free use



12 280-28 ☆
7" Disc

SI-2050AG Micro Grinder

- High speed angle head disc grinder with 30mm diameter disc
- 20,000rpm
- For exact and delicate work



13 340-57 ☆
30mm Grindstone

SI-2051SG Micro Grinder

- High speed die grinder with 3mm or 1/8" collet
- Low vibration and noise allows extended use
- Option : 1/8" Dia collet







14 340-2A ☆
3mm Collet

15 340-2B ☆
1/8" Collet

16 340-55 ☆
5mm Grindstone(3mm)

17 340-55A ☆
5mm Grindstone(1/8")

Model Number	Disc Size mm/(in.)	Spindle Size	Free Speed rpm (MAX)	Output Watt	Weight kg/(lb)	Noise Level dBA/ (power)	Vibration m/s ²	Avg. Air Consumption CFM
SI-2600L	180/(7")	M10×1.5	7,500	754	3.24/(7.15)	98/(110)	< 2.5	4.0
SI-2050AG	ø30	M7×0.75	20,000	—	0.23/(0.52)	83/(96)	< 2.5	1.1
Model Number	Collet Size	Free Speed rpm (MAX)	Weight kg/(lb)	Noise Level dBA/ (power)	Vibration m/s ²	Avg. Air Consumption CFM		
SI-2051SG	ø3 , 1/8"	50,000	0.19/(0.43)	78/(91)	< 2.5	1.0		

GRINDER ACCESSORIES

330-24 1/4" Collet	330-19 6mm Collet	330-25 1/8" Collet	330-26 3mm Collet	210-5-1A Dead handle set
175-29 3" Cut Disc	240-6 4" Disc 15mm Hole	240-71 4" Disc 16mm Hole	240C-1 Disc Nut for 16mm Hole	380-44 Disc Nut for 15mm Hole
241-49 5" Disc	280-28 7" Disc	340-57 30mm Grindstone	340-2A 3mm Collet	340-2B 1/8" Collet
340-55 5mm Grindstone(3mm)	340-55A 5mm Grindstone(1/8")			

**DRILLS
/ SPOT MILLS**

SI-2015AD

Drill

- 3/8" capacity geared straight grip drill
- Specially designed tool for use in narrow place



01 KD-004 (3/8" Drill Chuck w/Handle KK) ★

02 LX10 ☆ 10 210-5-1A ☆

Chuck Handle (Yukiwa)

SI-5100A

Drill

- 3/8" capacity geared pistol grip drill
- High speed drill for soft metal



01 KD-004 (3/8" Drill Chuck w/Handle KK) ★

02 LX10 ☆

Chuck Handle (Yukiwa)

SI-5200A

Drill

- 1/2" capacity, geared, pistol grip drill
- 500rpm low speed and high torque
- Ergonomic, compact, lightweight design with feather touch trigger for easy drill bit centering
- Precise planetary gear mechanism with needle roller assures high power, durability and reducing vibration
- Side handle for greater hand grip and control for easy operation



04 KD-003A (1/2" Drill Chuck w/Handle KK) ★

03 LM13W ☆ 10 210-5-1A ☆

Chuck Handle (Yukiwa)

SI-5300A

Drill

- 3/8" capacity geared pistol grip drill
- Heavy duty and the best selling model of the drills
- Precise planetary gear mechanism with needle roller assures high power, durability and reducing vibration
- Ergonomic, compact, lightweight design with feather touch trigger for easy centering



01 KD-004 (3/8" Drill Chuck w/Handle KK) ★

02 LX10 ☆

Chuck Handle (Yukiwa)

SI-5305A

Drill

- 3/8" capacity geared pistol grip reversible drill
- Handy reverse mechanism
- Can be used for tapping work by utilizing the reverse function



01 KD-004 (3/8" Drill Chuck w/Handle KK) ★

02 LX10 ☆ 08 100 ☆ 10 210-5-1A ☆

Chuck Handle (Yukiwa)

SI-5305-8A

Drill

- 1/2" capacity geared pistol grip reversible drill. 800rpm low speed and high torque. Handy reverse mechanism
- Can be used for tapping work by utilizing the reverse function
- Side handle for greater hand grip and control for easy operation



04 KD-003A (1/2" Drill Chuck w/Handle KK) ★

03 LM13W ☆ 10 210-5-1A ☆

Chuck Handle (Yukiwa)

Model Number	Free Speed rpm	Chuck Size mm/(in.)	Spindle Size	Drilling Cap mm/(in.)	Out Put Watt	Weight kg/(lb)	Noise Level dBA/(power)	Vibration m/s ²	Avg. Air Consumption CFM	Hose Size mm/(in.)
SI-2015AD	6,000	10/(3/8)	3/8-24UNF	6/(1/4)	457	1.06/(2.34)	94/(106)	< 2.5	4.2	10/(3/8)
SI-5100A	5,000	10/(3/8)	3/8-24UNF	6/(1/4)	390	0.90/(1.99)	90/(102)	< 2.5	3.3	10/(3/8)
SI-5200A	600	13/(1/2)	3/8-24UNF	13/(1/2)	390	1.42/(3.12)	88/(101)	< 2.5	3.5	10/(3/8)
SI-5300A	2,000	10/(3/8)	3/8-24UNF	10/(3/8)	378	0.91/(2.01)	90/(102)	< 2.5	3.6	10/(3/8)
SI-5305A	2,000	10/(3/8)	3/8-24UNF	10/(3/8)	326	1.02/(2.24)	94/(106)	< 2.5	3.9	10/(3/8)
SI-5305-8A	800	13/(1/2)	3/8-24UNF	13/(1/2)	326	1.45/(3.20)	94/(107)	< 2.5	4.2	10/(3/8)

SI-5501

Drill

- 3/8" capacity geared pistol grip drill
- Super light weight & compact design with solid composite body
- Based on two-layer molded rubber grip giving comfortable grip and reducing vibration
- A swivel lever for regulator can be used with one hand allowing easy operation



05 KD-002 (3/8" Drill Chuck w/Handle KG1) ★

02 LX10 ☆

Regulator Lever Chuck Handle (Yukiwa)

SI-5506

Drill

- 3/8" capacity geared pistol grip type reverse drill
- Super light weight & compact design with solid composite body
- Based on two-layer molded rubber grip giving comfortable grip and reducing vibration
- A swivel lever for forward & reverse can be used with one hand allowing easy operation



05 KD-002 (3/8" Drill Chuck w/Handle KG1) ★

02 LX10 ☆

Reverse Lever Chuck Handle (Yukiwa)

SI-5405

Drill

- Triple idler planetary gearing for smooth operation and extended tool life.
- Body end mounted reverse lever for one hand directional changes.
- High quality 3/8" chuck.



01 KD-004 (3/8" Drill Chuck w/Handle KK) ★

02 LX10 ☆ 08 100 ☆ 10 210-5-1A ☆

Chuck Handle (Yukiwa)

SI-5405-6

Drill

- Side handle assures easy operation and prevent wrist from injuries.
- Double reduction mechanism for exceptional power.
- 1/2" capacity standard rated grill chuck.



04 KD-003A (1/2" Drill Chuck w/Handle KK) ★

03 LM13W ☆ 10 210-5-1A ☆

Chuck Handle (Yukiwa)

SI-5500

Drill

- 3/8" capacity geared pistol grip drill
- Light duty and reasonable price model
- Ergonomic, compact and lightweight design for easy operation



05 KD-002 (3/8" Drill Chuck w/Handle KG1) ★

02 LX10 ☆

Chuck Handle (Yukiwa)

SI-5505

Drill

- 3/8" capacity geared pistol grip drill with solid composite body
- Supplied with keyless chuck
- Solid composite body absorbs the vibration remarkably and also protects your hand in a cold environment
- Keyless chuck enable the quick change of drill bits



02 LX10 ☆

01 KD-004 (3/8" Drill Chuck w/Handle KK) ☆

Chuck Handle (Yukiwa)

Model Number	Free Speed rpm	Chuck Size mm/(in.)	Spindle Size	Drilling Cap mm/(in.)	Out Put Watt	Weight kg/(lb)	Noise Level dBA/(power)	Vibration m/s ²	Avg. Air Consumption CFM	Hose Size mm/(in.)
SI-5501	2,400	10/(3/8)	3/8-24UNF	10/(3/8)	234	0.60/(1.32)	82/(95)	< 2.5	2.2	10/(3/8)
SI-5506	1,700	10/(3/8)	3/8-24UNF	10/(3/8)	146	0.60/(1.32)	81/(94)	< 2.5	2.4	10/(3/8)
SI-5405	1,500	10/(3/8)	3/8-24UNF	10/(3/8)	197	1.08/(2.38)	83/(96)	< 2.5	2.4	10/(3/8)
SI-5405-6	600	13/(1/2)	3/8-24UNF	13/(1/2)	186	1.41/(3.10)	82/(94)	< 4.0	2.3	13/(1/2)
SI-5500	2,600	10/(3/8)	3/8-24UNF	10/(3/8)	258	0.79/(1.75)	90/(103)	< 2.5	2.5	10/(3/8)
SI-5505	1,900	10/(3/8)	—	10/(3/8)	158	0.75/(1.65)	86/(99)	< 2.5	2.6	10/(3/8)

DRILLS / SPOT MILLS

SI-5355

Drill

- 3/8" capacity geared angle head drill
- Designed to facilitate drilling in confined places

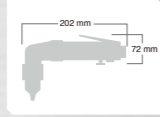

SI-5800

Spot Mill

- Specially designed to remove spot welds on body panels of motorcars. Work guide makes easy operation
- Easy to adjust depth of cut
- Special designed tool for spot welding separation
- With ø8mm Mill
- With sleeve for ø65mm Mill

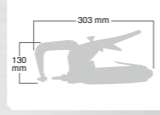

SI-5850

Spot Mill

- Specially designed to remove spot welds on body panel of motorcars
- Work guide makes easy operation
- Easy to adjust depth of cut
- Special designed tool for spot welding separation
- With ø8mm Mill

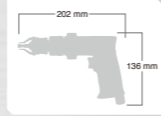

Model Number	Free Speed rpm	Chuck Size mm/(in.)	Spindle Size	Drilling Cap mm/(in.)	Out Put Watt	Weight kg/(lb)	Noise Level dBA/ (power)	Vibration m/s ²	Avg. Air Consumption CFM	Hose Size mm/ (in.)
SI-5355	1,200	10/(3/8)	3/8-24UNF	10/(3/8)	180	0.94/(2.07)	88/(101)	< 2.5	3.0	10/ (3/8)
Model Number	Free Speed rpm	Chuck Size mm/(in.)	Spindle Size	Milling Cap mm/(in.)	Out Put Watt	Weight kg/(lb)	Noise Level dBA/ (power)	Vibration m/s ²	Avg. Air Consumption CFM	Hose Size mm/ (in.)
SI-5800	1,600	8/(5/8)	ø8	8/(5/16)	197	1.80/(3.96)	85/(98)	< 2.5	3.0	10/ (3/8)
SI-5850	2,000	8/(5/8)	ø8	8/(5/16)	390	1.39/(3.06)	85/(98)	< 2.5	1.3	10/ (3/8)

DRILLS / SPOT MILLS ACCESSORIES

KD-004

Chuck / Handle

Chuck / Handle



3/8" Drill Chuck w / Handle KK 01

LX10

(Yukiwa)

Chuck



3/8" Cap. Keyless Chuck (3/8" Thd.) Optional 02

LM13W

(Yukiwa)

Chuck



1/2" Cap. Keyless Chuck (3/8" Thd.) Optional 03

KD-003A

Chuck / Handle

Chuck / Handle



1/2" Drill Chuck w / Handle KK 04

KD-002

Chuck / Handle

Chuck / Handle



3/8" Drill Chuck w / Handle KG1 05

KK

Handle



Chuck Handle for KD-004, SM8K61 & KD-003A 06

KG1

Handle



Chuck Handle for KD-002 & SM4G61 07

100

Sleeve Chuck



Collet Driver 08

271-17

Milling Cutter



ø8mm Milling Cutter 09

210-5-1A

Dead Handle set



Dead Handle set 10

CUTTING TOOLS

SI-4700B

Saw

- This air saw is the most popular tool for cutting body panel of motorcars and is one of longest selling models in the automotive repair market
- A popular tool at reasonable price

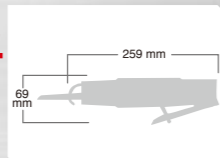

SI-4700B

Standard Accessories	
506-49A	Saw blade 32T
Option Accessories	
1025-49A	Saw blade 32T
1025-50A	Saw blade 24T

SI-4710

Saw

SI-4710F : Saw blade and 3files set

- Air saw & file
- An improved model over the SI-4700B
- You can use saw blades, as well as 3 different files with this tool
- Low vibration and high power

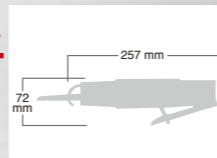

SI-4710

Standard Accessories	
506-49A	Saw blade 32T
Option Accessories	
1025-49	Saw blade 32T
1025-50	Saw blade 24T
506P-56F	Flat file
506P-56R	Round file
506P-56T	Triangle file

SI-4710F : Saw Blade and 3files set

Standard Accessories	
506-49A	Saw blade 32T
506P-56F	Flat file
506P-56R	Round file
506P-56T	Triangle file
Option Accessories	
1025-49A	Saw blade 32T
1025-50A	Saw blade 24T

SI-4730

Saw

- Air saw & file with rotary motor
- SI-4700B & SI-4710 are worked by piston but this model has a rotary air motor and makes working strokes through the gears
- Smooth operation, low vibration and low noise
- Amazing non-stop cutting with extremely low use fatigue

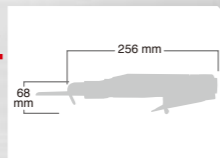

SI-4730

Standard Accessories	
1025-49A	Saw blade 32T
Option Accessories	
1025-50A	Saw blade 24T
506P-56F	Flat file
506P-56R	Round file
506P-56T	Triangle file

NEW SI-4740

Saw

- World's smallest and lightest air saw
- Easy to use in tight place
- This model mechanism is same with the SI-4730, worked by rotary air motor and makes working strokes through the gears
- Only 5mm strokes and other parts are not damaged

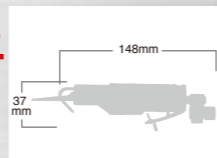

SI-4740

Standard Accessories	
1026-49A	Saw blade 32T
1026-50	Swivel Regulator
Option Accessories	
506P-56F	Flat file
506P-56R	Round file
506P-56T	Triangle file

SI-4300

Oscillation Cutter

- Oscillation cutting tool specially designed to cut the body panels of motorcars
- Two different cutting blades are supplied with the tool
- Specially designed tool for car repair shop
- The depth of the cut can be adjusted

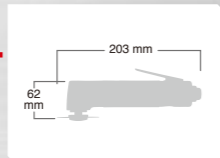

12 508-45A ★	13 508-45B ★	18 508-44 ★
--------------	--------------	-------------

SI-4600

Nibbler

- Air nibbler for cutting sheet metal
- The use of a punch and die makes cutting metal quick
- Can be used to cut in a curved line

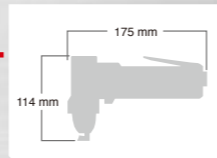

10 502-42 ★	11 502-41 ★
-------------	-------------

Model Number	File Shank Opening mm/(in.)	Cutting cap mm/(in.)	Stroke length mm	Free Speed s.p.m	Out Put W	Weight kg/(lb)	Noise Level dBA/(power)	Vibration m/s ²	Avg. Air Consumption CFM	Air Inlet Size in.	Hose Size mm/(in.)
SI-4700B	—	3/(1/8)	10mm	10,000	—	0.58/(1.27)	76/(89)	8.0	1.2	1/4	10/(3/8)
SI-4710/4710F	5/(3/16)	3/(1/8)	10mm	10,000	—	0.80/(1.76)	87/(100)	7.9	1.0	1/4	10/(3/8)
SI-4730	5/(3/16)	5/(3/16)	9mm	6,000	296	0.92/(2.03)	89/(101)	8.0	3.0	1/4	10/(3/8)
SI-4740	5/(3/16)	4/(5/32)	5mm	10,500	135	0.52/(1.15)	76/(87)	8.4	1.7	1/4	10/(3/8)
Model Number	Disc Size mm	Oscillating Angle	—	Free Speed rpm	Out Put W	Weight kg/(lb)	Noise Level dBA/(power)	Vibration m/s ²	Avg. Air Consumption CFM	Air Inlet Size in.	Hose Size mm/(in.)
SI-4300	ø63	2.8°	—	20,000	—	0.89	90/(103)	4.0	3.2	1/4	10/(3/8)
Model Number	Cutting Width mm/(in.)	Cutting cap mm/(in.)	—	Free Speed rpm	Out Put W	Weight kg/(lb)	Noise Level dBA/(power)	Vibration m/s ²	Avg. Air Consumption CFM	Air Inlet Size in.	Hose Size mm/(in.)
SI-4600	4.5/(3/16)	1.6/(1/16)	—	2,600	316	1.00/(2.20)	94/(106)	<2.5	3.3	1/4	10/(3/8)

SI-4500

Shear

- Air shear
- 3 blades shear head makes smooth cutting work for sheet metal
- For speedy cutting of sheet metal

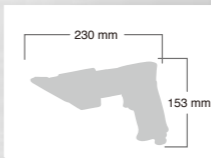

07/08/09 Blade Set 160-2, 3, 4 ★

160-2	160-3	160-4
-------	-------	-------

SI-2018A

Trimmer

SI-2018A-6 : 6mm Collet model

- Straight die grinder with work guide for trimming laminate
- Easy trimming work for woodwork products
- Designed for use in woodworking where a light weight, compact design is useful
- With 1/4" collet

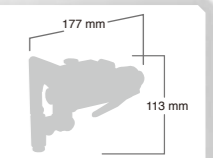

14 330-24	15 330-19
16 330-25	17 330-26

Model Number	Cutting Width mm/(in.)	Cutting cap mm/(in.)	Free Speed rpm	Out Put W	Weight kg/(lb)	Noise Level dBA/(power)	Vibration m/s ²	Avg. Air Consumption CFM	Air Inlet Size in.	Hose Size mm/(in.)
SI-4500	5.4/(7/32)	1.6/(1/16)	2,600	378	1.26/(2.79)	91/(104)	4.0	3.5	1/4	10/(3/8)
Model Number	Collet Size	Free Speed rpm	Output Watt	Weight kg/(lb)	Noise Level dBA/(power)	Vibration m/s ²	Avg. Air Consumption CFM			
SI-2018A/2018A-6	ø1/4" / ø6	22,000	381	0.91/(2.01)	96/(109)	< 2.5	4.2			

CUTTING TOOL ACCESSORIES

506-49A Saw blade 32T 01	1025-49A Saw blade 32T 02	1025-50A Saw blade 24T 03	506P-56F Flat File 04	506P-56R Round File 05
506P-56T Triangle File 06	160-2 Center Blade 07	160-3 Right Blade 08	160-4 Left Blade 09	502-42 Punch 10
502-41 Die 11	508-45A Cutting Wheel 12	508-45B Cutting Blade 13	330-24 1/4" Collet 14	330-19 6mm Collet 15
330-25 1/8" Collet 16	330-26 3mm Collet 17	508-44 Adjuster 18	1026-49A Saw blade 32T 19	1026-50 Swivel Regulator 20



OTHERS

OTHERS / AIR HAMMER

★ : Attachment Included
☆ : Accessories

SI-4120A

Air Hammer

- Pistol grip air hammer for 10.2mm diameter chisels (.401" shank)
- Many kinds of the chisels are available as accessories
- High speed piston power of 2,600 times per min
- Powerful piston enable the tool to cope with many kinds of work

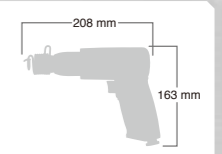

01 400-8 ★



Model Number	Shank Size in./ (mm)	Stroke length mm	Free Blow Speed spm	Weight kg/ (lb)	Noise Level dBA/ (power)	Vibration m/s ²	Avg. Air Consumption CFM	Air Inlet Size in.	Hose Size mm/ (in.)	Type of Shank
SI-4120A	.401/(10.2)	Max 10	2,600	1.60/(3.52)	104/(116)	9.0	3.0	1/4	10/ (3/8)	Round

AIR HAMMER ACCESSORIES

Special Accessories .401 Shank CHISELS

All products are Made in Japan.

No.801		TIE ROD TOOL	No.813		RIVET CUTTER
No.802		TAIL PIPE CUTTER	No.814		BLANK CHISEL
No.803		FORK 21/23" OPENING	No.815		SPOT WELD BREAKER
No.803J		FORK 15/16" OPENING	No.816		SHEET METAL B
No.804		BUSHING REMOVER	No.817		BUSHING DRIVER
No.805		SCRAPER	No.818		FLAT BEND
No.806		BUSHING SPLITTER	No.819		SHEET METAL PUNCH
No.807		SHEET METAL A	No.820		PANEL CLIPPER
No.808		MUFFLER CUTTER	No.821		SMOOTHING HAMMER
No.809		DOUBLE EDGE PANEL CUTTER	No.822		STRAIGHT PUNCH
No.810		FLAT 7" LONG	No.823		PAINT SCRAPER
No.811		FLAT 9" LONG	No.824		SHOCK ABSORBER CHISEL
No.812		TAPER PUNCH	No.825		MOIL POINT

IMPACT WRENCHES
DRIVERS
RATCHET WRENCHES
SANDERS
POLISHER
GRINDERS
DRILLS/SPOTMILLS
CUTTING TOOLS
OTHERS
MAINTENANCE CHECK
QUALITY
ACCESSORIES

SI-4150 Needle Scaler

- Straight grip needle scaler for removing rust or old paint. It provides very good working on uneven or rough surface
- Resign grip for a soft feeling to the hand and improved comfort in winter or cold climate regions
- Mechanism actuated by air power only, not using springs reduces reaction time and improves the smooth actuation
- Simple mechanism provides easy maintenance and needle replacement

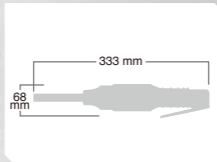

02 820-11 ★



SI-4800 Hydro Puncher

- Punching and flanging tool is useful for panel beating work
- Best tool for welding work of car body

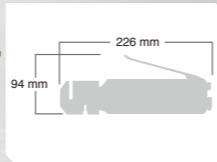

Model Number	Stroke length mm	Free Blow Speed spm	Weight kg/(lb)	Noise Level dBA/(power)	Vibration m/s ²	Avg. Air Consumption CFM	Air Inlet Size in.	Hose Size mm/(in.)
SI-4150	Max 4.5	3,500	2.06/(4.53)	97/(107)	13.0	1.3	1/4	10/(3/8)
Model Number	Punching cap	Cutting cap mm/(in.)	Weight kg/(lb)	Vibration m/s ²	Avg. Air Consumption CFM	Air Inlet Size in.	Hose Size mm/(in.)	
SI-4800	ø5 x 1.2mm	1.2/(3/64)	1.01/(2.23)	< 2.5	1.3	1/4	10/(3/8)	

OTHERS
ACCESSORIES

400-8

Retaining Spring



01

820-11

Needle

ø3 x 180mm



12 Needles / product

02

MAINTENANCE CHECK

AIR TOOLS

In order to have a tool safely used with enough performance, please read the following contents well, understand them and use tools.

WORK STATIONS

The tool should only be use as a handheld tool. It is always recommended that the tool is used when standing on a solid floor. It can be used in other positions, but before any such use the operator must be in a secure position having a firm grip and be aware of the extra safety precaution required when using this kind of tools.

AIR SUPPLY

Use a clean lubricated air supply that will give a measured air pressure at the tools of 0.63Mpa(6.3 bar/90PSI) when the tool is running with the trigger depressed. Use recommended hose size and length. It is recommended that the tool is connected to the air supply as shown in the figure. Don't connect the tool to the airline system without incorporating an easy to reach and operate air shut off valve. The air filter, regulator and lubricated air at the correct pressure to the tool. Details of such equipment can be obtained from your supplier. If such equipment is not used then the tool should be lubricated by operator before/after using the tool. Disconnect the airline and pour into the inlet bushing 5ml of the suitable pneumatic oil preferably incorporating a rust inhibitor. Reconnect tool to air supply and run tool slowly for a few seconds to allow air to circulate the oil.

DESCRIPTION

Pressure at the working	0.63MPa (90PSI 6.3bar)
Max Hose Length	10m (30ft)
Lubrication	Daily Lubricating oil

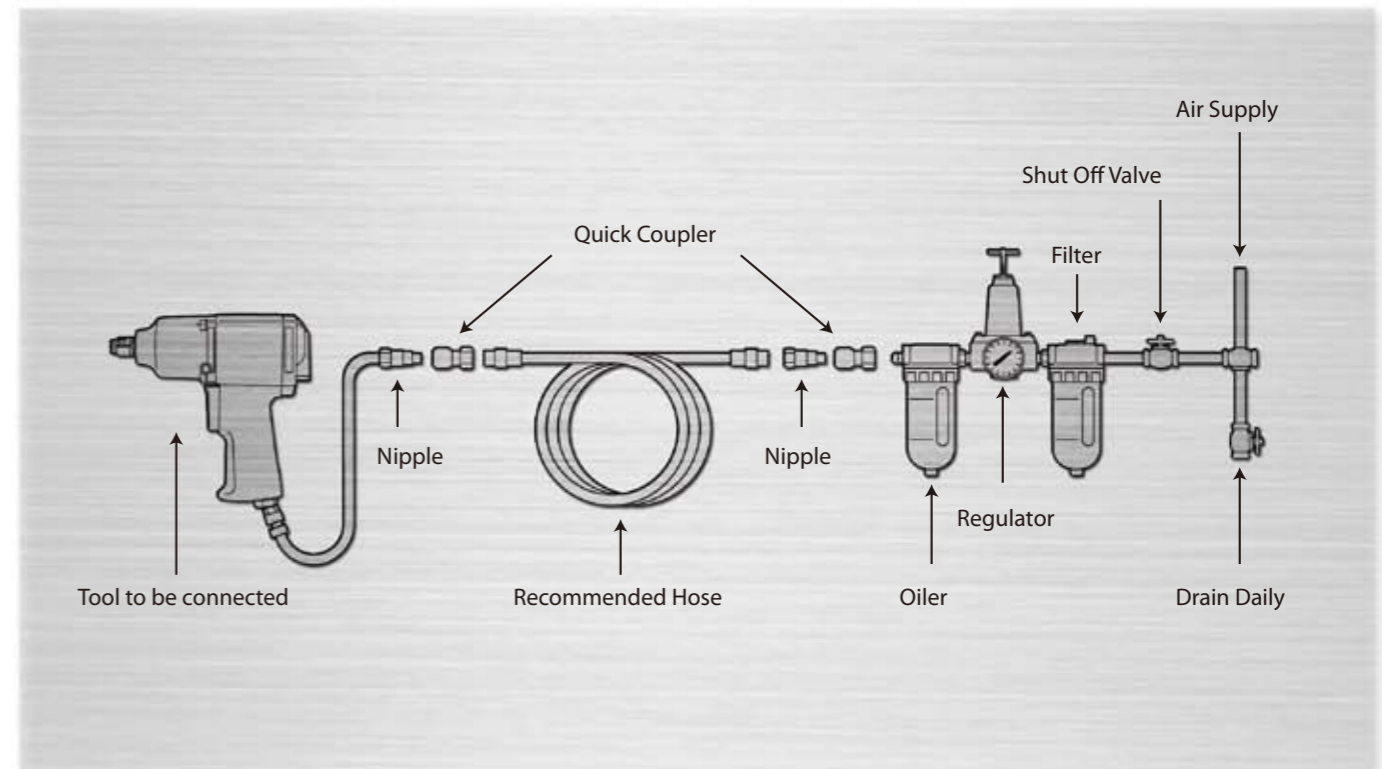

Planning And Development

For Customer's Satisfaction

In our products planning meetings our professional staff analyzes data from pertinent industries.

We discuss product concepts, target markets, sales prices, designs, functions, specifications and timing of introductions.



Designing

For Highest Perfection

In designing, we carefully study the properties of each part.

We examine the matings of each component in an assembled motor, and test the strength.

Our designers always aim for perfection in their designs which may eliminate inspections of product.

Our designs are based on ergonomics. "SI" collects data and tests experiments for safety, health and higher productivity.



Production

More Accurate, Rapid And Efficient

We are innovating our production lines to assist all automatic robotics in manufacturing products more accurately, rapidly and effectively.

We believe that it is important to combine robot hand at high productivity with the management of the human mind, in order to sell quality products at an affordable price.



Inspection

To Certify The Quality

There is no need to inspect the function of each product because they have been carefully checked to produce perfection by design.

Our inspection of parts and products is not for defect detection, but to insure that the product meets the required quality and durability standard.

Our inspector's day-by-day studies assure you of higher quality of our products.

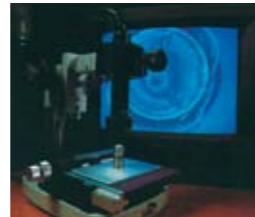

Exhaust Hose

TYPE-A

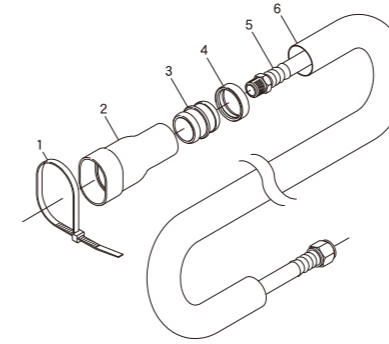

Ref. No.	Parts No.	Description	Q' ty
1	106-10	Harness Band	1
2	106-5	Exhaust Cover A	1
3	106-6	Connector	1
4	106-1	Urethane Band	1
5	106-3	Wipe Hose	1
6	106-2	Exhaust Hose	1
NO.1~6	106-A	Wipe Hose A Assy	1

TYPE-B

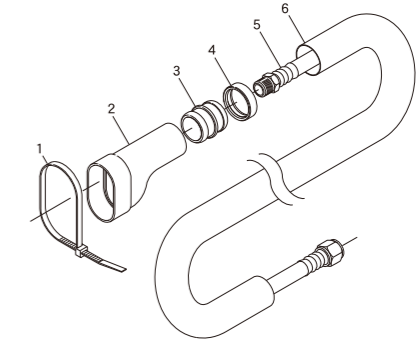

Ref. No.	Parts No.	Description	Q' ty
1	106-10	Harness Band	1
2	106-7	Exhaust Cover B	1
3	106-6	Connector	1
4	106-1	Urethane Band	1
5	106-3	Wipe Hose	1
6	106-2	Exhaust Hose	1
NO.1~6	106-B	Wipe Hose B Assy	1

TYPE-D

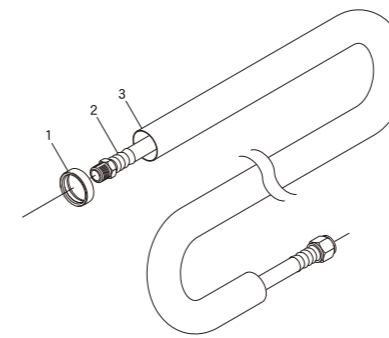

Ref. No.	Parts No.	Description	Q' ty
1	106-1	Urethane Band	1
2	106-3	Wipe Hose	1
3	106-2	Exhaust Hose	1
NO.1~3	106-D	Wipe Hose D Assy	1

TYPE-S

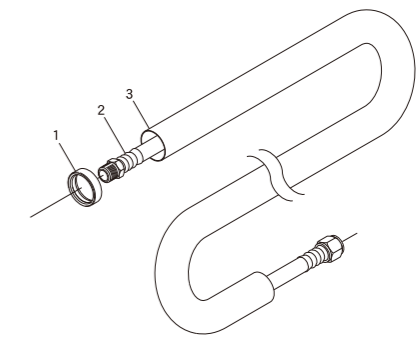

Ref. No.	Parts No.	Description	Q' ty
1	106-8	Urethane Band S	1
2	106-3	Wipe Hose	1
3	106-9	Exhaust Hose S	1
NO.1~3	106-S	Wipe Hose S Assy	1

Exhaust House	IMPACT WRENCHES				DRIVERS				RATCHET WRENCHES				SANDERS				POLISHER												
	SI-13170S	SI-13185S	SI-14900A	SI-14920A	SI-14900SR	SI-1440T	SI-1442T	SI-1060	SI-1070	SI-1365D	SI-1161	SI-1168A	SI-1168R	SI-1340B	SI-1345B	SI-2107A	SI-2008	SI-2110	SI-2026	SI-2201	SI-2202	SI-2351	SI-2700	SI-2700LS	SI-2800	SI-2830	SI-3200A	SI-3200(H)	
TYPE-A																													
TYPE-B																													
TYPE-D																													
TYPE-S																													

Exhaust House	DIE GRINDER/DISC GRINDER				DRILLS/SPOTMILLS								CUTTING TOOLS															
	SI-2011A	SI-2012A	SI-2015A	SI-2016A	SI-2017A	SI-2018A	SI-2019A	SI-2020A	SI-2021A	SI-2022A	SI-2023A	SI-2024A	SI-2025A	SI-2026A	SI-2027A	SI-2028A	SI-2029A	SI-2030A	SI-2031A	SI-2032A	SI-2033A	SI-2034A	SI-2035A	SI-2036A	SI-2037A	SI-2038A	SI-2039A	SI-2040A
TYPE-A																												
TYPE-B																												
TYPE-D																												
TYPE-S																												

IMPACT WRENCHES
DRIVERS
RATCHET WRENCHES
SANDERS
POLISHER
GRINDERS
DRILLS/SPOTMILLS
CUTTING TOOLS
OTHERS
MAINTENANCE CHECK
QUALITY
ACCESSORIES

