

**LENOX** 

# CATALOGUE

2015



## WHAT THE LENOX® HERITAGE OF QUALITY AND PERFORMANCE MEANS FOR YOU.

The LENOX® name is inspired by the speed, strength and sharp teeth of the wolves that once roamed the hills near the western shore of Loch Lomond in Scotland - home to the Earl of LENOX®.

2015 marks 100 years of the LENOX® brand, we began our company in 1915, making the first LENOX® hacksaw blades with just ten employees. Now, over 98 years later, LENOX® remains dedicated to producing the highest quality, best performing cutting products. As a result, we have grown to employ more than 700 people.

Most of them work at our ISO 9001 certified facility in East Longmeadow, Massachusetts, U.S.A., where we design, test and manufacture a broad range of power tool accessories and hand tools. Professionals count on the performance of our products in more than 70 countries around the world.

We continue to invest in our facilities, strongly supporting research and development and integrating the most advanced manufacturing technology. The result is the breakthrough performance and endurance of our newest products - including our LENOX® Speed Slot T2 Hole Saw.

Above all, we are committed to fully meeting the needs of our customers and ensuring complete satisfaction with our products and services. If you are new to LENOX®, thank you for the opportunity to earn your business.

## Contents

	Page
<b>Power Tool Accessories</b>	<b>4</b>
Reciprocating Saw Blades	4
Bi-Metal Hole Saws	12
Diamond® Hole Saws	14
Carbide Tipped Hole Saws	15
Hole Saw accessories and parts	15
Hole Saw and accessories	16
Vari-Bit Step Drill Bits	19
Jigsaw Blades	20
<b>Hand Tools</b>	<b>22</b>
Hacksaw Frames & Blades	22
Handsaws	25
Plastic Tubing Cutters	26
Metal Tubing Cutters	28
<b>Index</b>	<b>30</b>





**1959**

Hole Saws added to the product line



**1977**

Hand Tools and Power Tool Accessories added to the product line to launch the tool division of LENOX®



**1977**

First Bi-Metal Reciprocating Saw Blade made by Lee HACKMAN® Breton using the same technology used to make Band Saw Blades

**1996**

LENOX® achieved ISO 9001 certification making LENOX® the first in the blade industry to become certified

**Newell Rubbermaid**  
Brands That Matter

**2003**

LENOX® acquired by Newell Rubbermaid.

**2011**

Speed Slot Holesaws. Bi-metal Holesaws that are long lasting, fast cutting and versatile



**2014 - DUPLA**

Up to 2X longer blade vs standard blade

**2015**  
100 YEAR  
ANNIVERSARY

**1915**

LENOX® American Saw founded by John Swanson, Carl Ericson and Carl Davis with 10 employees manufacturing Hacksaw Blades on Taylor Street in Springfield, MA

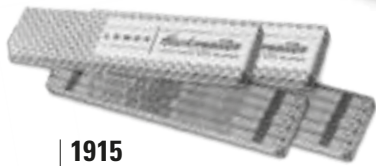

**1918**

Band Saw production begins



**1961**

LENOX® began manufacturing Band Saw Blades at the East Longmeadow facility



**1981**

HACKMAN® cut his first car in half using a LENOX® Hacksaw Blade. It took him 26 minutes, 6 seconds



**2008**

LENOX® T2™ Technology introduced to Reciprocating Blades



# HERITAGE

The LENOX® brand stands for breakthrough **PERFORMANCE**. It's enabled by uncompromising engineering, top-quality materials and manufacturing excellence—and supported by a team of experts focused 100 percent on your **SUCCESS**. That was true over 100 years ago. It's true today. And it's something you can always count on. Period.

# LENOX® Gold™

# POWER ARC™ CURVED BLADE

# NEW



# POWER ARC™ CURVED BLADE

FOR UP TO  
**2X**  
LIFE™

**NEW**

## LENOX Gold® Wood Cutting

Item No.	Description	EAN	Master Pack	Min. Order Qty Blades/Pack*
21060656GR	656G 152 x 19 x 1,3mm 6TPI	082472201606	500	5
21062956GR	956G 229 x 19 x 1,3mm 6TPI	082472201620	250	5
21061156GR	156G 305 x 19 x 1,3mm 6TPI	082472201613	250	5



## LENOX Gold® Metal Cutting

Item No.	Description	EAN	Master Pack	Min. Order Qty Blades/Pack*
21064610GR	610G 152 x 19 x 0,9mm 10TPI	082472210644	500	5
21065810GR	810G 203 x 19 x 1,3mm 10TPI	082472210651	250	5
21066414GR <sup>1</sup>	414G 102 x 19 x 0,9mm 14TPI	082472210668	500	5
21067614GR	614G 152 x 19 x 0,9mm 14TPI	082472210675	500	5
21068418GR <sup>1</sup>	418G 102 x 19 x 0,9mm 18TPI	082472210682	500	5
21069618GR	618G 152 x 19 x 0,9mm 18TPI	082472210699	500	5
21070818GR	818G 203 x 19 x 0,9mm 18TPI	082472210705	250	5
21071424GR <sup>1</sup>	424G 102 x 19 x 0,9mm 24TPI	082472210712	500	5
21072624GR	624G 152 x 19 x 0,9mm 24TPI	082472210729	500	5
21073824GR	824G 203 x 19 x 0,9mm 24TPI	082472210736	250	5

### LONGEST LASTING BLADE. EVER. EXTENDED BLADE LIFE

T2™ Technology and precision applied titanium coating help dissipate heat making blades last longer

### FASTER CUTS

Titanium coating makes teeth more wear resistant so they stay sharp for quicker cuts

### DURABLE CONSTRUCTION

Bi-metal design stands up to the most demanding applications

## LENOX Gold® Demolition

Item No.	Description	EAN	Master Pack	Min. Order Qty Blades/Pack*
210886066GR <sup>1</sup>	6066G 152 x 22 x 1,6mm 6TPI	082472210880	500	5
21089960GR	960G 229 x 22 x 1,6mm 10TPI	082472210897	250	5
21090966GR	966G 229 x 22 x 1,6mm 6TPI	082472210903	250	5
21091106GR	106G 305 x 22 x 1,6mm 6TPI	082472210910	250	5

### Why use the new T2™ Blades?

**Lasts longer:** Up to 100%\*\*

**Cuts faster:** Up to 25%\*\*

**Shatter resistant:** Bi-Metal

\*\*vs. previous LENOX® blades

**T2™ proprietary technology now available across the entire Gold Reciprocating Saw Blades line.**

## LENOX Gold® LAZER Heavy Metal Cutting

Item No.	Description	EAN	Master Pack	Min. Order Qty Blades/Pack*
210926108GR	6108G 152 x 25 x 1,1mm 8TPI	082472210927	500	5
210969108GR	9108G 229 x 25 x 1,1mm 8TPI	082472210965	250	5
210936110GR	6110G 152 x 25 x 1,1mm 10TPI	082472210934	500	5
210979110GR	9110G 229 x 25 x 1,1mm 10TPI	082472210972	250	5
2110012110GR	12110G 305 x 25 x 1,1mm 10TPI	082472211009	250	5
210946114GR	6114G 152 x 25 x 1,1mm 14TPI	082472210941	500	5
210989114GR	9114G 229 x 25 x 1,1mm 14TPI	082472210989	250	5
2110112114GR	12114G 305 x 25 x 1,1mm 14TPI	082472211016	250	5
210956118GR	6118G 152 x 25 x 1,1mm 18TPI	082472210958	500	5
210999118GR	9118G 229 x 25 x 1,1mm 18TPI	082472210996	250	5
2110212118GR	12118G 305 x 25 x 1,1mm 18TPI	082472211023	250	5

<sup>1</sup> Blades do not feature Power Arc technology.

\*Items can only be ordered in multiples of the Min. Order Quantity

### Bi-Metal Reciprocating Saw Blades

Long Lasting, Fast Cutting and Versatile

#### ENGINEERED FOR PERFORMANCE

The superior design minimizes friction and heat build-up while cutting through the widest variety of metal materials



#### T2™ TECHNOLOGY

A revolutionary new blade design that delivers up to 100% longer blade life and 25% faster performance versus the prior generation of LENOX® Reciprocating Saw Blades



### Standard Bi-Metal Reciprocating Saw Blades

#### T2™ TECHNOLOGY

Tooth design delivers up to 2x the life versus previous model

#### OPTIMISED BLADE GEOMETRY

Each blade has a unique configuration including an aggressive tang angle and tapered blade shape to allow for cutting in tight areas

#### ENGINEERED FOR PERFORMANCE

Special design minimises friction and heat build up while cutting through the widest variety of metal materials

Item No.	Description	EAN	Master Pack	Min. Order Qty
20550414R	414R 102 x 19 x 0,9mm 14TPI	082472205503	500	5
20552418R	418R 102 x 19 x 0,9mm 18TPI	082472205527	500	5
20554424R	424R 102 x 19 x 0,9mm 24TPI	082472205541	500	5
20575634R	634R 152 x 19 x 1,3mm 4TPI	082472205756	500	5
20556676RC	676RC 152 x 11 x 1,3mm 6TPI, Contour Cutting	082472205565	500	5
20560606R	606R 152 x 19 x 0,9mm 6TPI	082472205602	500	5
20572656R	656R 152 x 19 x 1,3mm 6TPI	082472205725	500	5
20570636RP	636RP 152 x 19 x 1,3mm 6TPI, Plaster Cutting	082472205701	500	5
148216J6R	6J6R 152 x 19 x 1,3mm 6TPI, Drywall (repl. for 20997EU Tri-Fold™ Saw)	082472148213	90	1
20582956R	956R 229 x 19 x 1,3mm 6TPI	082472205824	250	5
20585156R	156R 305 x 19 x 1,3mm 6TPI	082472205855	250	5
20562610R	610R 152 x 19 x 0,9mm 10TPI	082472205626	500	5
20580810R	810R 203 x 19 x 1,3mm 10TPI	082472205800	250	5
20583110R	110R 305 x 19 x 1,3mm 10/14TPI	082472205831	250	5
20564614R	614R 152 x 19 x 0,9mm 14TPI	082472205640	500	5
21519814R	814R 203 x 19 x 0,9mm 14TPI	082472215199	250	5
20566618R	618R 152 x 19 x 0,9mm 18TPI	082472205664	500	5
20578818R	818R 203 x 19 x 0,9mm 18TPI	082472205787	250	5
21510118R	118R 305 x 19 x 1,3mm 18TPI	082472215106	250	5
20568624R	624R 152 x 19 x 0,9mm 24TPI	082472205688	500	5
20579824R	824R 203 x 19 x 0,9mm 24TPI	082472205794	250	5
205308656R	B656R 152 x 19 x 1,3mm 6TPI	082472205305	500	25
205588956R	B956R 229 x 19 x 1,3mm 6TPI	082472205589	250	25
205908810R	B810R 203 x 19 x 1,3mm 10TPI	082472205909	250	25
204938610R	B610R 152 x 19 x 0,9mm 10TPI	082472204933	500	25
204918110R	B110R 305 x 19 x 1,3mm 10/14TPI	082472204919	250	25
204948614R	B614R 152 x 19 x 0,9mm 14TPI	082472204940	500	25
205298618R	B618R 152 x 19 x 0,9mm 18TPI	082472205299	500	25
204878818R	B818R 203 x 19 x 0,9mm 18TPI	082472204872	250	25
215118118R	B118R 305 x 19 x 0,9mm 18TPI	082472215113	250	25

## Multi Material Reciprocating Saw Blades



Item No.	Description	EAN	Master Pack	Min. Order Qty Blades/Pack*
1769340	635R 152 x 19 x 0,9mm 10/14TPI	5706915078565	500	5
1769341	835R 203 x 19 x 0,9mm 10/14TPI	5706915078572	250	5

### Why use the new T2™ Blades?

**Lasts longer:** Up to 100%\*\*

**Cuts faster:** Up to 25%\*\*

**Shatter resistant:** Bi-Metal

\*\*vs. previous Lenox blades

**T2™ proprietary technology**

T2™ now available on 6, 10, 10/14, 14, 18 and 24TPI on the wood and metal blades

## LAZER® Reciprocating Saw Blades



Item No.	Description	EAN	Master Pack	Min. Order Qty Blades/Pack*
201706110R	6110R 152 x 25 x 1,1mm 10TPI	082472201703	500	5
201726114R	6114R 152 x 25 x 1,1mm 14TPI	082472201727	500	5
201746118R	6118R 152 x 25 x 1,1mm 18TPI	082472201741	350	5
201769110R	9110R 229 x 25 x 1,1mm 10TPI	082472201765	250	5
201789114R	9114R 229 x 25 x 1,1mm 14TPI	082472201789	250	5
201809118R	9118R 229 x 25 x 1,1mm 18TPI	082472201802	200	5
2018212110R	12110R 305 x 25 x 1,1mm 10TPI	082472201826	250	5
2018412114R	12114R 305 x 25 x 1,1mm 14TPI	082472201840	250	5
2019012118R	12118R 305 x 25 x 1,1mm 18TPI	082472201901	200	5
20185B12114R	12114R 305 x 25 x 1,1mm 14TPI	082472201857	250	25

**Longer lasting:** Lasts 45% longer than standard bi-metal blades

**Greater strength and durability:** Unique blade geometry reinforces traditional weak areas, creating stronger and more durable blades

**Shatter resistant:** Bi-metal blades bend and resist breaking and extend blade life

**Optimised performance:** Thicker (1.1 mm) and wider (25 mm) blades minimise whipping for straighter and smoother cuts

T2™ proprietary technology now available across the entire LAZER Reciprocating Saw Blades line.

## Demolition Reciprocating Saw Blades



Item No.	Description	EAN	Master Pack	Min. Order Qty Blades/Pack*
20598966R	966R 229 x 28 x 1,6mm 6TPI	082472205985	120	2
20371966R5	966R 229 x 28 x 1,6mm 6TPI	082472203714	250	5
20500106R	106R 305 x 28 x 1,6mm 6TPI	082472205008	120	2
20597960R	960R 229 x 28 x 1,6mm 10TPI	082472205978	120	2
20372960R5	960R 229 x 28 x 1,6mm 10TPI	082472203721	250	5
20523B966R	966R 229 x 28 x 1,6mm 6TPI	082472205237	250	25
20524B960R	960R 229 x 28 x 1,6mm 10TPI	082472205244	250	25

### T2™ TECHNOLOGY

Tooth design delivers up to 2x the life versus previous model making demolition jobs faster and easier

### MAXIMUM DURABILITY

The tallest blade on the market (28mm) prevents bending and provides maximum control in the toughest demolition applications

### OPTIMISED BLADE GEOMETRY

Each blade has a unique configuration including an aggressive tang angle and tapered blade shape to allow for cutting in tight areas

**T2™ proprietary technology now available across the entire Demolition Reciprocating Saw Blades line.**

\*Items can only be ordered in multiples of the Min. Order Quantity





### Fire & Rescue Reciprocating Saw Blades



**Shatter resistant:** Bi-Metal blades bend and resist breaking and extend blade life  
**Optimised performance:** Thicker (1,3mm) blades minimise whipping for straighter and smoother cuts  
**Extreme versatility:** Designed to cut easily through the toughest materials. Cuts dimensional lumber, angle iron, fasteners and metal pipe - simultaneously

Item No.	Description	EAN	Master Pack	Min. Order Qty Blades/Pack*
20592650R	650R 152 x 19 x 1,3mm 10/14TPI	082472205923	240	2
20374650R5	650R 152 x 19 x 1,3mm 10/14TPI	082472203745	500	5
20577850R	850R 203 x 19 x 1,3mm 10/14TPI	082472205770	250	5
20515B650R	650R 152 x 19 x 1,3mm 10/14TPI	082472205152	500	25

### Reciprocating Saw Blade Kits



1073415RKG



1214412RKD

Item No.	Description	EAN	Master Pack	Min. Order Qty
121439KPE	9 Piece Wood & Metal Kit: 2x 656R, 2x 624R, 2x 810R, 2x 818R, 1x 960R	082472121438	10	1
1214412RKD	12 Piece Demolition Kit: 3x 6066R, 3x 6114R, 2x 9114R, 2x 966R, 2x 960R	082472121445	10	1
1497913RKM	13 Piece Metal Kit: 3x 614R, 3x 618R, 2x 818G, 3x 818R, 2x 960R	5706915077056	10	1
1498013RKW	13 Piece Wood Kit: 3x 656R, 3x 610R, 2x 966G, 2x 966R, 3x 810R	5706915077049	10	1
1073415RKG	15RKG 15 Piece Wood & Metal : 5 x 614R, 5 x 618R, 5 x 656R	082472107340	8	1

\*Items can only be ordered in multiples of the Min. Order Quantity



## DIAMOND™ Grit Reciprocating Saw Blades



**Cuts Cast. Fast.**  
**Cuts 3x faster\*\*** Narrowed kerf edge removes a thinner cross-section of material for faster cutting  
**Lasts 3x longer\*\*** Industrial diamonds embedded in high-strength nickel alloy braze  
 \*\*compared to LENOX® carbide grit recips

Item No.	Description	EAN	Master Pack	Min. Order Qty Blades/Pack*
10833800RDG	800RDG 200 x 19 x 1mm Diamond Grit, Single Tang	082472108330	90	1
1766338	800DTDG 225 x 19 x 1mm Diamond Grit, <b>Double Tang</b>	885363000740	90	1
1766356	100DTDG 275 x 19 x 1mm Diamond Grit, <b>Double Tang</b>	885363000757	90	1



**NEW**

**New Double Tang:** Allows end user to flip blade around, reducing amount of wasted grit and maximising cost per cut.

## Master-Grit™ Blades



Item No.	Description	EAN	Master Pack	Min. Order Qty Blades/Pack*
20505600RG	600RG 152 x 20 x 0,8mm, Carbide Grit	082472205053	240	2
20506100RG	100RG 254 x 20 x 1,3mm, Carbide Grit	082472205060	100	2
20576800RG	800RG 203 x 20 x 1,0mm, Carbide Grit	082472205763	100	2

**Long lasting:** Super hard (RA 90-93) cutting edge cuts through even the toughest materials  
**Abrasive cutting:** Cuts through cast iron, fibreglass, ceramic tile, clay, pipe, stone, brick, plaster and marble  
**Smooth cutting:** MASTER-GRIT™ does not snag or chip, providing smooth cuts

## Carbide Tipped Reciprocating Saw Blades



Item No.	Description	EAN	Master Pack	Min. Order Qty Blades/Pack*
205956563RCT	6563RCT 152 x 19 x 1,3mm 6TPI, Contour Bk	082472205954	150	1
205966565RCT	6565RCT 152 x 19 x 1,3mm 6TPI, Straight Bk	082472205961	150	1
205998535RCT	8535RCT 203 x 19 x 1,3mm 3TPI, Straight Bk	082472205992	100	1

**Fast cutting** LENOX® triple chip tooth grind cuts 25% faster than standard carbide blades.

**Extreme performance** Designed to cut through fibreglass, cement board, rubber and other difficult to cut materials.

\*Items can only be ordered in multiples of the Min. Order Quantity



**Fast, durable and precise cutting in all masonry materials** 5 TPI blades for high-quality cuts in clay brick, limestone and Poroton blocks 1.5 TPI blades for high-quality cuts in light and aerated concrete

### Carbide Tipped Masonry Reciprocating Blades

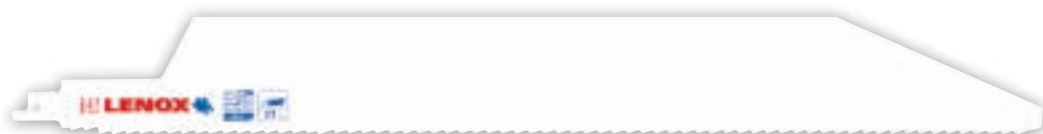

Item No.	Description	EAN	Master Pack	Min. Order Qty Blades/Pack*
21103235BLP	235BLP 235 x 20 x 1,2 5TPI	5706915078497	25	1
21104300BLP	300BLP 300 x 50 x 1,2 5TPI	5706915078503	25	1
21105450BLP	450BLP 450 x 50 x 1,2 5TPI	5706915078510	25	1
21107300LC	300LC 300 x 50 x 1,2 1,5TPI	5706915078534	25	1
21108450LC	450LC 450 x 50 x 1,2 1,5TPI	5706915078541	25	1

### Pallet Cutting Bi-Metal Reciprocating Saw Blades



Item No.	Description	EAN	Master Pack	Min. Order Qty Blades/Pack*
10729810RPC	810RPC 200 x 19 x 0,9mm 10TPI	082472107296	250	250
107301010RPC	1010RPC 250 x 19 x 0,9mm 10TPI	082472107302	250	250

### Air Saw Blades

**Shatter resistant:** Bi-Metal blades bend and resist breaking and extend blade life  
**Maximum durability:** For pneumatic machine cutting  
**Long lasting:** High-speed Steel teeth provide a strong, long lasting cutting edge



Item No.	Description	EAN	Master Pack	Min. Order Qty Blades/Pack*
20427424T	424T 100 x 13 x 0,64mm 24TPI	082472204278	500	5
20428432T	432T 100 x 13 x 0,64mm 32TPI	082472204285	500	5

\*Items can only be ordered in multiples of the Min. Order Quantity

## Reciprocating Saw Blade Selection Guide

	WOOD	NAIL-EMBEDDED WOOD	NON-FERROUS METAL	DEMOLITION	FIRE & RESCUE	PLASTICS & COMPOSITES	THICK METAL	MEDIUM METAL	THIN METAL	DRYWALL/ PLASTER	CEMENT BOARD	CAST IRON	ABRASIVES
<b>BEST</b>	LENOX Gold®									CARBIDE TIPPED	LENOX DIAMOND™		
<b>BETTER</b>	BI-METAL	LAZER®	BI-METAL				LAZER		BI-METAL	LENOX DIAMOND™	CARBIDE GRIT		
<b>GOOD</b>	—	BI-METAL	—				BI-METAL		—	CARBIDE GRIT	—		

## Teeth Per Inch Selection Guide

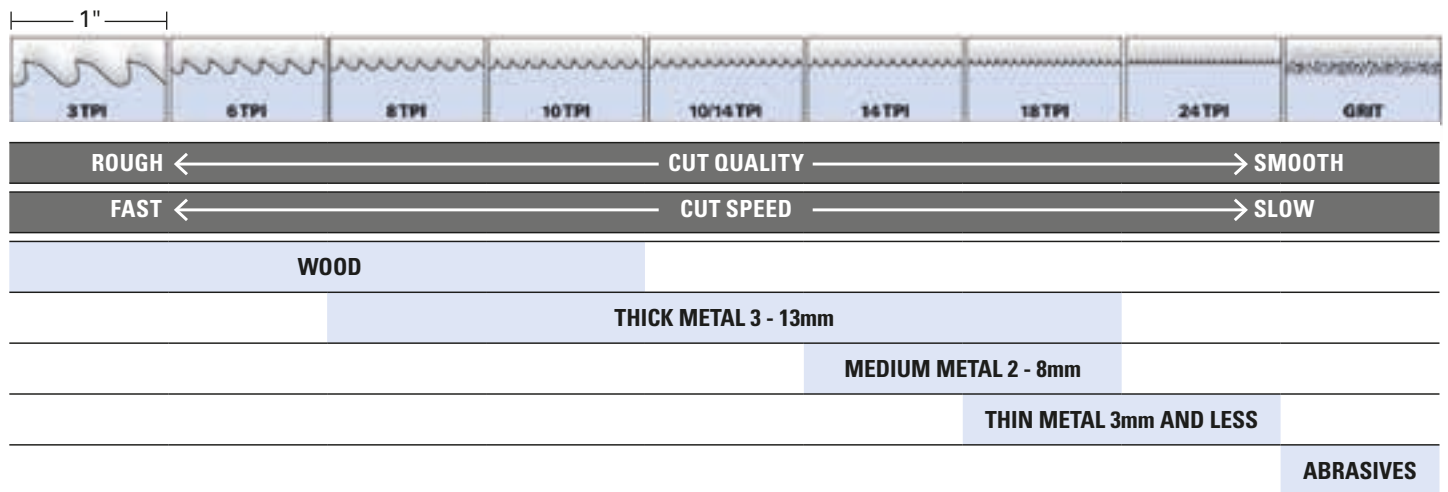

## Blade Length Selection Guide

Always keep 2 teeth in the cut.

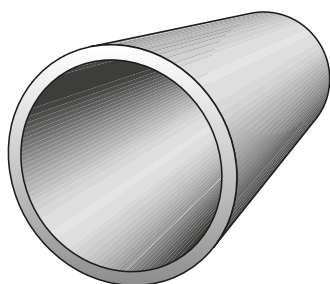

← WIDTH →

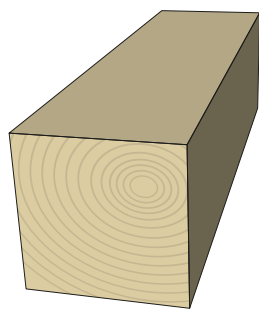

← WIDTH →

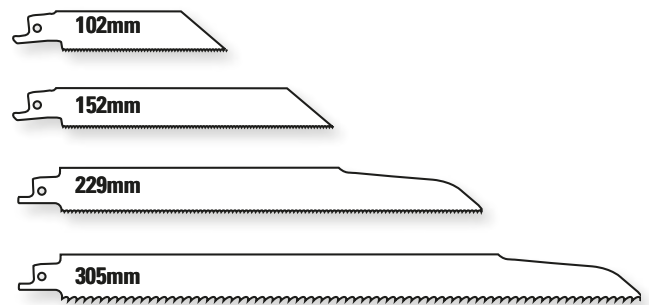

WIDTH OF MATERIAL + 76mm = BLADE LENGTH

EXAMPLE: 127mm (WIDTH) + 76mm = 203mm.

USE AN 203mm OR 229mm BLADE



Technology



### Bi-Metal **SPEED SLOT®** Hole Saws

Long Lasting, Fast Cutting And Versatile

#### SPEED SLOT®

Unique staircase design for easy plug removal

#### UP TO 2X LIFE IN METAL CUTTING

Enhanced tooth geometry, a thin kerf design, and an advanced coating contribute to the efficiency of the cutting process

#### CUTTING EFFICIENCY

The hole saw is 10 percent taller than the previous model to deliver cleaner cuts through two-by-lumber.

#### RESISTS TOOTH STRIPPAGE

Bi-Metal construction creates a hardened edge to minimise tooth stripping.

Use standard or SNAP-BACK arbor

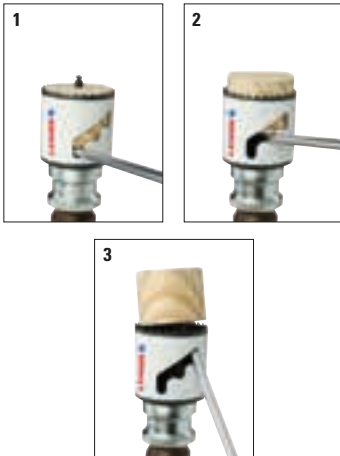

Item No.	Description	Fits Arbor No.	EAN	Master Pack	Min. Order Qty
300099L	9L 14mm	1L, 4L or 5L	082472300093	10	1
3001010L	10L 16mm	1L, 4L or 5L	082472300109	10	1
3001111L	11L 17mm	1L, 4L or 5L	082472300116	10	1
3001212L	12L 19mm	1L, 4L or 5L	082472300123	10	1
3009820MMHS	20MM 20mm	1L, 4L or 5L	082472300987	10	1
3001313L	13L 21mm	1L, 4L or 5L	082472300130	10	1
3001414L	14L 22mm	1L, 4L or 5L	082472300147	10	1
3001515L	15L 24mm	1L, 4L or 5L	082472300154	10	1
3001616L	16L 25mm	1L, 4L or 5L	082472300161	10	1
3001717L	17L 27mm	1L, 4L or 5L	082472300178	10	1
3001818L	18L 29mm	1L, 4L or 5L	082472300185	10	1
3001919L	19L 30mm	1L, 4L or 5L	082472300192	10	1
3002020L	20L 32mm	2L, 3L or 6L	082472300208	10	1
3002121L	21L 33mm	2L, 3L or 6L	082472300215	10	1
3002222L	22L 35mm	2L, 3L or 6L	082472300222	10	1
3002323L	23L 37mm	2L, 3L or 6L	082472300239	10	1
3002424L	24L 38mm	2L, 3L, 6L or 7L	082472300246	10	1
3002525L	25L 40mm	2L, 3L, 6L or 7L	082472300253	10	1
3002626L	26L 41mm	2L, 3L, 6L or 7L	082472300260	10	1
3002727L	27L 43mm	2L, 3L, 6L or 7L	082472300277	10	1
3002828L	28L 44mm	2L, 3L, 6L or 7L	082472300284	10	1
3002929L	29L 46mm	2L, 3L, 6L or 7L	082472300291	5	1
3003030L	30L 48mm	2L, 3L, 6L or 7L	082472300307	5	1
3003232L	32L 51mm	2L, 3L, 6L or 7L	082472300321	5	1
3003333L	33L 52mm	2L, 3L, 6L or 7L	082472300338	5	1
3003434L	34L 54mm	2L, 3L, 6L or 7L	082472300345	5	1
1816241	35L 56mm	2L, 3L, 6L or 7L	0885363008951	5	1
3003636L	36L 57mm	2L, 3L, 6L or 7L	082472300369	5	1
3003838L	38L 60mm	2L, 3L, 6L or 7L	082472300383	5	1



## Bi-Metal **SPEED SLOT**<sup>®</sup> Hole Saws

Item No.	Description	Fits Arbor No.	EAN	Master Pack	Min. Order Qty
1816242	39L 62mm	2L, 3L, 6L or 7L	0885363008968	5	1
3004040L	40L 64mm	2L, 3L, 6L or 7L	082472300406	5	1
3004141L	41L 65mm	2L, 3L, 6L or 7L	082472300413	5	1
3004242L	42L 67mm	2L, 3L, 6L or 7L	082472300420	5	1
3004343L	43L 68mm	2L, 3L, 6L or 7L	082472300437	5	1
3004444L	44L 70mm	2L, 3L, 6L or 7L	082472300444	5	1
3004646L	46L 73mm	2L, 3L, 6L or 7L	082472300468	5	1
3004848L	48L 76mm	2L, 3L, 6L or 7L	082472300482	5	1
3005050L	50L 79mm	2L, 3L, 6L or 7L	082472300505	5	1
3005252L	52L 83mm	2L, 3L, 6L or 7L	082472300529	5	1
3005454L	54L 86mm	2L, 3L, 6L or 7L	082472300543	5	1
3005656L	56L 89mm	2L, 3L, 6L or 7L	082472300567	5	1
3005858L	58L 92mm	2L, 3L, 6L or 7L	082472300581	1	1
3006060L	60L 95mm	2L, 3L, 6L or 7L	082472300604	1	1
3006262L	62L 98mm	2L, 3L, 6L or 7L	082472300628	1	1
3006464L	64L 102mm	2L, 3L, 6L or 7L	082472300642	1	1
3006666L	66L 105mm	2L, 3L, 6L or 7L	082472300666	1	1
3006868L	68L 108mm	2L, 3L, 6L or 7L	082472300680	1	1
3007070L	70L 111mm	2L, 3L, 6L or 7L	082472300703	1	1
3007272L	72L 114mm	2L, 3L, 6L or 7L	082472300727	1	1
3007474L	74L 118mm	2L, 3L, 6L or 7L	082472300741	1	1
3007676L	76L 121mm	2L, 3L, 6L or 7L	082472300765	1	1
3008080L	80L 127mm	2L, 3L, 6L or 7L	082472300802	1	1
1816243	83L 133mm	2L, 3L, 6L or 7L	0885363008975	1	1
3008888L	88L 140mm	2L, 3L, 6L or 7L	082472300888	1	1
1816245	92L 146mm	2L, 3L, 6L or 7L	0885363008982	1	1
3009696L	96L 152mm	2L, 3L, 6L or 7L	082472300963	1	1
3106106L	106L 168mm	2L, 3L, 6L or 7L	5706915081633	1	1
3112112L	112L 177mm	2L, 3L, 6L or 7L	5706915081640	1	1
3132132L	132L 210mm	2L, 3L, 6L or 7L	5706915081657	1	1



## Bi-Metal **SPEED SLOT**<sup>®</sup> Hole Saws Kits

Item No.	Description	EAN	Master Pack	Min. Order Qty
1768436	9 pcs Plumber's Hole Saw Kit: 19, 22, 29, 38, 44, 68mm, Arbors: 2L, 5L, 1 x Arbor Adapter	5706915078022	-	1
1768556	17 pcs Electrician's Hole Saw Kit: 16, 19, 22, 25, 29, 32, 35, 38, 44, 51, 68, 76mm, Arbors: 1L, 2L, 2 x 4321 Pilot Drill Bits, 1 x 56PD Pilot Drill Bit	5706915078046	-	1
1768559	21 pcs Electrician's Hole Saw Kit: 19, 22, 25, 29, 35, 38, 44, 51, 57, 68, 76, 83, 92, 95, 105, 121mm, Arbors: 1L, 2L, 2 x 4321 Pilot Drill Bits, 1 x 56PD Pilot Drill Bit	5706915078053	-	1
1768662	8 pcs Electrician's Hole Saw Kit: 16, 20, 25, 32, 38, 51mm, Arbors: 1L, 2L	5706915078060	-	1
1768668	9 pcs Electrician's Hole Saw Kit: 16, 20, 25, 32, 41, 51, 64mm, Arbors: 1L, 2L	5706915078077	-	1
1768695	17 pcs Electrician's Hole Saw Kit: 19, 22, 29, 35, 44, 51, 64, 68, 76, 92, 105, 121mm, Arbors: 2L, 5L, 2 x 4321 Pilot Drill Bits, 1 x 56PD Pilot Drill Bit	5706915078107	-	1
1768696	10 pcs Electrician's Hole Saw Kit: 22, 29, 35, 44, 51, 64mm, Arbors: 2L, 5L, 1 x 4321 Pilot Drill Bit, 1 x Arbor Adapter	5706915078114	-	1
1768698	26 pcs Big Daddy™ Hole Saw Kit: 19, 22, 25, 29, 35, 38, 44, 51, 54, 57, 64, 68, 76, 83, 86, 92, 95, 105, 114, 121mm, Arbors: 1L, 2L, 5L, 2 x 4321 Pilot Drill Bits, 1 x 56PD Pilot Drill Bit	5706915078121	-	1
1768793	9 pcs General Purpose Hole Saw Kit: 22, 25, 32, 35, 38, 44, 54mm, Arbors: 5L, 6L	5706915078138	-	1
1768794	10 pcs Plumber's Hole Saw Kit: 19, 22, 29, 38, 44, 57mm Arbors: 2L, 5L, 1 x 4321 Pilot Drill Bit, 1 x Arbor Adapter	5706915078145	-	1
1768795	17 pcs General Purpose Hole Saw Kit: 16, 19, 22, 25, 29, 32, 35, 38, 44, 51, 64, 76mm, Arbors: 1L, 2L, 3 x 4321 Pilot Drill Bits	5706915078152	-	1



## DIAMOND™

The complete solution for cutting holes in porcelain, ceramics, granite, marble, glass, slate, fiberglass, travertine, cement board



**Note:** Each LENOX® DIAMOND™ Holesaw shelf pack contains a carbide tipped pilot drill bit and a hex key. Please read the usage instructions for high-quality cutting results.

## LENOX DIAMOND™ Hole Saws

More Holes. Less Time

### LONG LASTING

Brazed diamond edge for more holes in tile and stone

### DURABLE

Robust design for greater durability in tough applications

### FAST CUTTING

Cuts holes in less time than carbide grit or carbide tipped hole saws

### EASIER PLUG REMOVAL

Round holes make removing plugs faster and easier

### USE STANDARD ARBOR OR SNAP-BACK™ ARBOR



Item No.	Description	Fits Arbor No.	EAN	Master Pack	Min. Order Qty
10507823	DHS 19mm	1L, 4L or 5L	5706915078237	100	1
10507824	DHS 20mm	1L, 4L or 5L	5706915078244	100	1
10507825	DHS 22mm	1L, 4L or 5L	5706915078251	100	1
10507826	DHS 25mm	1L, 4L or 5L	5706915078268	100	1
10507827	DHS 29mm	1L, 4L or 5L	5706915078275	50	1
10507828	DHS 32mm	1L, 4L or 5L	5706915078282	50	1
10507829	DHS 35mm	2L, 3L or 6L	5706915078299	50	1
10507830	DHS 38mm	2L, 3L or 6L	5706915078305	50	1
10507831	DHS 44mm	2L, 3L, 6L or 7L	5706915078312	50	1
10507832	DHS 48mm	2L, 3L, 6L or 7L	5706915078329	50	1
10507833	DHS 51mm	2L, 3L, 6L or 7L	5706915078336	50	1
10507834	DHS 54mm	2L, 3L, 6L or 7L	5706915078343	50	1
10507835	DHS 57mm	2L, 3L, 6L or 7L	5706915078350	50	1
10507836	DHS 60mm	2L, 3L, 6L or 7L	5706915078367	50	1
10507837	DHS 64mm	2L, 3L, 6L or 7L	5706915078374	50	1
10507838	DHS 68mm	2L, 3L, 6L or 7L	5706915078381	50	1
10507839	DHS 76mm	2L, 3L, 6L or 7L	5706915078398	50	1
10507840	DHS 83mm	2L, 3L, 6L or 7L	5706915078404	20	1
10507841	DHS 102mm	2L, 3L, 6L or 7L	5706915078411	20	1
10507842	DHS 114mm	2L, 3L, 6L or 7L	5706915078428	20	1

## Carbide Tipped Hole Saws

Item No.	Description	Fits Arbor No.	EAN	Master Pack	Min. Order Qty
3021111CT	11CT 17mm	1L, 4L or 5L	082472302110	10	1
3021212CT	12CT 19mm	1L, 4L or 5L	082472302127	10	1
3021414CT	14CT 22mm	1L, 4L or 5L	082472302141	10	1
3021616CT	16CT 25mm	1L, 4L or 5L	082472302165	10	1
3021818CT	18CT 29mm	1L, 4L or 5L	082472302189	10	1
3022020CT	20CT 32mm	2L, 3L or 6L	082472302202	10	1
3022222CT	22CT 35mm	2L, 3L or 6L	082472302226	10	1
3022424CT	24CT 38mm	2L, 3L, 6L or 7L	082472302240	10	1
3022626CT	26CT 41mm	2L, 3L, 6L or 7L	082472302264	10	1
3022828CT	28CT 44mm	2L, 3L, 6L or 7L	082472302288	10	1
3023232CT	32CT 51mm	2L, 3L, 6L or 7L	082472302325	5	1
3023434CT	34CT 54mm	2L, 3L, 6L or 7L	082472302349	5	1
3023636CT	36CT 57mm	2L, 3L, 6L or 7L	082472302363	5	1
3023838CT	38CT 60mm	2L, 3L, 6L or 7L	082472302387	5	1
3024040CT	40CT 64mm	2L, 3L, 6L or 7L	082472302400	5	1
3024141CT	41CT 65mm	2L, 3L, 6L or 7L	082472302417	5	1
3024242CT	42CT 67mm	2L, 3L, 6L or 7L	082472302424	5	1
3024343CT	43CT 68mm	2L, 3L, 6L or 7L	082472302431	5	1
3024848CT	48CT 76mm	2L, 3L, 6L or 7L	082472302486	5	1
3025252CT	52CT 83mm	2L, 3L, 6L or 7L	082472302523	5	1
3025454CT	54CT 86mm	2L, 3L, 6L or 7L	082472302547	5	1
3025656CT	56CT 89mm	2L, 3L, 6L or 7L	082472302561	5	1
3025858CT	58CT 92mm	2L, 3L, 6L or 7L	082472302585	-	1
3026060CT	60CT 95mm	2L, 3L, 6L or 7L	082472302608	-	1
3026464CT	64CT 102mm	2L, 3L, 6L or 7L	082472302646	-	1
3026666CT	66CT 105mm	2L, 3L, 6L or 7L	082472302660	-	1
3026868CT	68CT 108mm	2L, 3L, 6L or 7L	082472302684	-	1
3027272CT	72CT 114mm	2L, 3L, 6L or 7L	082472302721	-	1
3027676CT	76CT 121mm	2L, 3L, 6L or 7L	082472302769	-	1
3028080CT	80CT 127mm	2L, 3L, 6L or 7L	082472302806	-	1
3028888CT	88CT 140mm	2L, 3L, 6L or 7L	082472302882	-	1
3029696CT	96CT 152mm	2L, 3L, 6L or 7L	082472302967	-	1

**Long tool life:** Heat-resistant carbide teeth for long life in tile and stainless steel

**Added durability:** Thick backing plate resists damage and increases life

**Unique tooth configuration:** Engineered design provides ability to cut stainless steel like no other

**Use standard or SNAP-BACK arbor**

**Note:** We recommend the use of a carbide tipped pilot drill when cutting ceramic wall tile. Pilot drill 123CT fits the 1L, 2L, 4L or 7L arbors. Pilot drill 65CTPD fits the 5L and 6L arbors



## Hole Saw Accessories & Parts

Item No.	Description	Chuck Size mm	Fits Arbor No.	EAN	Master Pack	Min. Order Qty
30297123CT	123CT Carbide Tip Pilot Drill	6	1L/2L/4L/7L	082472302974	250	1
3029865CTPD	65CTPD Carbide Tip Pilot Drill	6	3L/5L/6L/7L	082472302981	150	1
10507941	Pilot Drill Bit Diamond Hole Saw	6	1L/2L/3L/4L/5L/6L/7L	5706915079418	250	1
1779771	4321 Pilot Drill, long 10,7cm	6	1L/2L/4L	885363004663	250	1
1779810	56PD Pilot Drill, short 8,2cm	6	3L/5L/6L/7L	885363004823	250	1
3084310X	250mm Extension	10 +	5L/6L/7L	082472308433	20	1
3084712X	300mm Extension	13 +	1L/2L/3L	082472308471	20	1
3084818X	450mm Extension	13 +	1L/2L/3L	082472308488	20	1
30857AA1	Arbor Adaptor*	-	1L/4L/5L	082472308570	100	1

\* Arbor Adaptor: To fit 32mm and bigger hole saws onto 1L, 4L and 5L (Standard & SNAP-BACK™) arbors



### SNAP-BACK™ Quick-Change Arbors

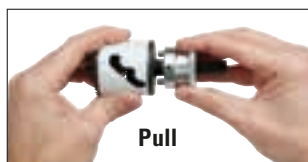

Item No.	Description	Shank Size mm	EAN	Master Pack	Min. Order Qty
1768811	Snap-Back 2L Quick-Change Arbor	12.7 & larger	5706915077667	-	1
1768812	Snap-Back 5L Quick-Change Arbor	9.5 & larger	5706915077674	-	1
1768813	Snap-Back 6L Quick-Change Arbor	9.5 & larger	5706915077681	-	1



### Standard Hole Saw Arbors

Item No.	Description	Fits Hole Saw Diameters	Shank Size mm	EAN	Master Pack	Min. Order Qty
1779774	1L Hex	14 - 30mm	12.7 & larger	885363004755	90	1
1779801	2L Hex	32 - 210mm	12.7 & larger	885363004762	90	1
1779802	3L Solid / Hex	32 - 210mm	12.7 & larger	885363004779	54	1
1779803	4L 3-Sided	14 - 30mm	6.4 & larger	885363004786	90	1
1779804	5L Hex	14 - 30mm	9.5 & larger	885363004793	90	1
1779805	6L Hex	30 - 210mm	9.5 & larger	885363004809	90	1
1779806	7L Hex	38 - 210mm	9.5 & larger	885363004816	65	1

**Added durability:** Hardened carbon steel for strength through the cross-section  
**Starts on contact:** Split-point pilot drill bit for faster penetration and less walking  
**Simple plug ejection:** 7L arbor is designed with sliding pins to easily eject plugs from hole saws



### PROTOOL LUBE™

**A unique synthetic blend designed to increase tool life:** When cutting, milling, reaming, tapping and drilling metal, wood and plastics











**Shortens cutting time by up to 50%:** Provides smoother, cleaner cutting and dramatically longer blade life

**Reduces heat and friction:** Water-soluble, so it cleans up with water. Bio-degradable and non-toxic

Item No.	Description	EAN	Master Pack	Min. Order Qty
68040LNX	ProTool Lube™ 0,17 litre, 12 pcs. in Display, English	082472680409	-	12
68047	ProTool Lube™ 3,8 litre English	082472680478	-	1
68081	ProTool Lube™ 0,17 litre Italian / Spanish	082472680812	-	12
68082	ProTool Lube™ 0,17 litre French	082472680829	-	12
68083	ProTool Lube™ 0,17 litre Portuguese	082472680836	-	12
68084	ProTool Lube™ 0,17 litre Swedish	082472680843	-	12

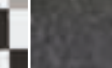

## Hole Saw Selection Guide

	WOOD	NAIL-EMBEDDED WOOD	NON-FERROUS	PLASTICS & COMPOSITES	METAL	STAINLESS STEEL	DRYWALL & PLASTER	CAST IRON	CEMENT BOARD	ABRASIVES	TILE	STONE
												
<b>BEST</b>	CARBIDE TIPPED								DIAMOND			
<b>BETTER</b>	BI-METAL							BI-METAL			CARBIDE TIPPED	

## Recommended Hole Saw RPM

### Bi-Metal

Diameter mm	Mild Steel	Tool & Stainless	Cast Iron	Brass	Alum
14	580	300	400	790	900
16	550	275	365	730	825
17	500	250	330	665	750
19	460	230	300	600	690
20	425	210	280	560	630
21	425	210	280	560	630
22	390	195	260	520	585
24	370	185	245	495	555
25	350	175	235	470	525
27	325	160	215	435	480
29	300	150	200	400	450
30	285	145	190	380	425
32	275	140	180	360	410
33	260	135	175	345	390
35	285	145	190	380	425
37	240	120	160	315	360
38	230	115	150	300	345
40	220	110	145	290	330
41	210	105	140	280	315
43	205	100	135	270	305
44	195	95	130	250	295
46	190	95	125	250	285
48	180	90	120	240	270
51	170	85	115	230	255
52	165	80	110	220	245
54	160	80	105	210	240
56	150	75	100	200	225
57	150	75	100	200	225
62	135	65	90	180	205
60	140	70	95	190	220

Diameter mm	Mild Steel	Tool & Stainless	Cast Iron	Brass	Alum
64	135	65	90	180	205
65	130	65	85	175	200
67	130	65	85	170	195
68	125	60	80	160	185
70	125	60	80	160	185
73	120	60	80	160	180
76	115	55	75	150	170
79	110	55	70	140	165
83	105	50	70	140	155
86	100	50	65	130	150
89	95	45	65	130	145
92	95	45	60	120	140
95	90	45	60	120	135
98	85	40	55	110	130
102	85	40	55	110	130
105	80	40	55	110	120
108	80	40	55	110	120
111	75	35	50	100	105
114	75	35	50	100	105
118	75	35	50	100	105
121	70	35	45	90	95
127	70	35	45	90	95
133	65	30	40	85	90
140	65	30	40	85	90
146	65	30	40	85	90
152	65	30	40	85	90
168	65	30	40	85	90
177	65	30	40	85	90
210	65	30	40	85	90



## Recommended Hole Saw RPM

### Diamond

Diameter mm	Ceramic Tiles, Fibreglass, Cement Board, Carbon Fibre, Slate, Granite, Marble	Glass
19-25	1500-2000	800-1200
29-44	1500-2000	500-900
48-57	1500-2000	400-800
60-76	1000-1500	200-600
83-114	600-1000	150-500

## Recommended Hole Saw RPM

### Carbide Tipped



**Note:** We recommend the use of a carbide tipped pilot drill when cutting ceramic wall tile.

Pilot drill 123CT fits the SNAP-BACK 2L or standard arbors 1L, 2L, 4L or 7L. Pilot drill 65CTPD fits the SNAP-BACK 2L or standard arbors 5L and 6L. See page 14.

Diameter mm	Aluminium	Plastic	Fibreglass	Ceramic Tile	Particle Board	Cast Iron
17mm	1700	3430	250	500	3430	410
19mm	1700	3430	250	500	3430	410
22mm	1500	2940	210	430	2940	180
25mm	1300	2570	190	370	2570	150
29mm	1100	2290	170	330	2290	140
32mm	1100	1870	140	270	1870	110
35mm	900	1870	140	270	1870	110
38mm	900	1710	120	250	1710	100
41mm	700	1710	120	250	1710	100
44mm	700	1470	110	210	1470	90
51mm	600	1290	90	190	1290	80
54mm	600	1140	90	190	1140	80
57mm	600	1140	80	170	1140	70
60mm	500	1030	80	170	1030	70
64mm	500	1030	70	150	1030	60
65mm	500	1030	70	150	1030	60
67mm	400	860	70	150	860	60
68mm	400	860	70	120	860	50
76mm	400	860	60	120	860	50
83mm	400	790	60	110	790	50
86mm	400	790	60	110	790	50
89mm	400	790	60	110	790	40
92mm	400	710	50	100	710	40
95mm	300	690	50	100	690	40
102mm	300	650	50	90	650	40
105mm	300	620	50	90	620	40
108mm	300	600	40	90	600	40
114mm	300	560	40	80	560	30
121mm	300	540	40	80	540	30
127mm	200	480	40	80	500	30
140mm	200	420	40	70	460	30
152mm	100	360	30	60	420	30

# Vari-Bit™ Step Drill Bits

## Vari-Bit™ Step Drill Bits



## Vari-Bit™ Step Drill Bits, Metric

Item No.	Description	Chuck Size	EAN	Master Pack	Min. Order Qty
30960MVB412	MVB412 9 steps 4, 5, 6, 7, 8, 9, 10, 11, 12mm	1/4" (6.35mm)	082472309607	-	1
30961MVB1424	MVB1424 7 steps 14, 16, 18, 20, 22, 24, 25mm	3/8" (9.5mm)	082472309614	-	1
30962MVB618	MVB618 7 steps 6, 8, 10, 12, 14, 16, 18mm	3/8" (9.5mm)	082472309621	-	1
30963MVB2034	MVB2034 8 steps 20, 22, 24, 26, 28, 30, 32, 34mm	3/8" (9.5mm)	082472309638	-	1
30964MVB528PG	MVB528PG 10 steps 5, 7.5, 10, 12.5, 15.2, 18.6, 20.4, 22.5, 25.5, 28.3mm	3/8" (9.5mm)	082472309645	-	1

**Accurate, burr-free holes:** Two flute design cuts fast, clean, round holes  
**Starts on contact:** Split-point design for faster penetration and less walking  
**Long tool life:** Steam oxide coating adds durability. Enhanced flute design removes chips rapidly. Use of LENOX® PROTOOL LUBE recommended to extend tool life

## Vari-Bit™ Step Drill Bits

Item No.	Description	Chuck Size	EAN	Master Pack	Min. Order Qty
30882VB2	VB2 9 steps 12.5, 14, 16, 17.5, 19, 20.5, 22, 23.5, 25mm	3/8" (9.5mm)	082472308822	-	1
30883VB3	VB3 9 steps 6, 8, 9.5, 11, 12.5, 14, 16, 17.5, 19mm	3/8" (9.5mm)	082472308839	-	1
30912VB12	VB12 5 steps 22, 28.5, 31, 32, 35mm	3/8" (9.5mm)	082472309126	-	1

## Bi-Metal Jig Saw Blades

Ideal for Wood Working and Metal Cutting

**Shatter resistant:** Bi-Metal technology flexes and resists breaking and extends blade life



**Smoother finish:** Ground to precision sharpness for straighter cuts and a smoother finish

**Greater precision:** Super sharp to cut fast without deflection

### PRECISION CUTTING

Super sharp to cut fast without deflection

### SMOOTH FINISH

Ground to precision sharpness for straight cuts and a smooth finish

### IDEAL FOR WOODWORKING

Designed for optimal performance in wood cutting, including hardwoods

### SHATTER RESISTANT

Bi-Metal technology flexes and resists breaking and extends blade life



T SHANK



UNIVERSAL SHANK

## Bi-Metal T-Shank Jigsaw Blades



Item No.	Description	EAN	Master Pack	Min. Order Qty Blades/Pack*
20305BT406S	406S 100 x 10 x 1,3mm 6TPI, Wood Cutting	082472203059	250	2
20306BT410S	410S 100 x 10 x 1,3mm 10TPI, Wood Cutting	082472203066	250	2
20309BT686S	686S 150 x 10 x 1,3mm 6TPI, Wood Cutting	082472203097	250	2
20311BT320	320SC 92 x 5 x 1,3mm 20TPI, Wood Cutting Contour	082472203110	250	2
20313BT450	450S 100 x 8 x 1,3mm 10TPI, Wood Cutting	082472203134	250	2
20314BT450	450SR 100 x 8 x 1,3mm 10TPI, Wood Cutting, Reverse Tooth Setting	082472203141	250	2
20315BT456	456S 100 x 8 x 1,3mm 6TPI, Wood Cutting	082472203158	250	2
20301BT314S	314S 92 x 10 x 0,9mm 14TPI, Metal Cutting	082472203011	250	2
20302BT318S	318S 92 x 10 x 0,9mm 18TPI, Metal Cutting	082472203028	250	2
20303BT324S	324S 92 x 10 x 0,9mm 24TPI, Metal Cutting	082472203035	250	2
20308BT518S	518S 135 x 10 x 1,3mm 18TPI, Metal Cutting	082472203080	250	2
20803BT332S	332S 92 x 10 x 0,9mm 32TPI, Metal Cutting	082472208030	250	2
20812B406S	406S 100 x 10 x 1,3mm 6TPI, Wood Cutting	082472208122	500	25
20813B410S	410S 100 x 10 x 1,3mm 10TPI, Wood Cutting	082472208139	500	25
20814B450S	450S 100 x 8 x 1,3mm 10TPI, Wood Cutting	082472208146	500	25



## High Carbon Steel Jig Saw Blades

Ideal for Woodworking

### PRECISION CUTTING

Super sharp to cut fast without deflection

### SMOOTH FINISH

Ground to precision sharpness for straight cuts and a smooth finish

### IDEAL FOR WOODWORKING

Designed for optimal performance in wood cutting, including hardwoods



T SHANK



UNIVERSAL SHANK



## Carbon T-Shank Jigsaw Blades for Wood Cutting



Item No.	Description	EAN	Master Pack	Min. Order Qty Blades/Pack*
20295CF450	CF450SR 100 x 10 x 1,5mm 10TPI, Wood Cutting, Reverse Tooth Setting	082472202953	500	5
20296CF450	CF450S 100 x 10 x 1,5mm 10TPI, Wood Cutting	082472202960	500	5
20298CFS406S	CFS406S 100 x 10 x 1,3mm 6TPI, Wood Cutting	082472202984	500	5
20312BT416	416SC 100 x 6 x 1,3mm 6TPI, Wood Cutting Contour	082472203127	250	2
20299CF320	CF320SC 92 x 6 x 1,3mm 20TPI, Wood Cutting Contour	082472202991	500	5



## Jigsaw Kit

Item No.	Description	EAN	Master Pack	Min. Order Qty Blades/Pack*
1802081	Jigsaw Kit: 4x 406S, 4x 456S, 4x 450S, 2x 324S	885363006582	100	1

## Carbide Grit T-Shank Jigsaw Blades



Item No.	Description	EAN	Master Pack	Min. Order Qty Blades/Pack*
20300GT300S	300S 75 x 8 x 0,8mm Abrasive cutting	082472203004	250	2

**Longer lasting performance** in abrasive materials: fiberglass, tile, brick

## DIAMOND™ T-Shank Jigsaw Blades



Item No.	Description	EAN	Master Pack	Min. Order Qty Blades/Pack*
12149DG300S	300S 75 x 8 x 0,8mm Diamond Grit	082472121490	125	1

**Diamond cutting edge** lasts longer and cuts faster than Carbide Grit blades  
**Ideal solution** for cutting hardest tiles

\*Items can only be ordered in multiples of the Min. Order Quantity

**Convenient blade storage:** Safely fold blade into handle

**Compact design:** Fits easily into pocket or tool box

**Replaceable blades:** Uses any standard reciprocating saw blade

**Rugged design:** Heavy-duty aluminium handle has a comfortable hand grip

**Multi-purpose:** Push button design locks blade into three different positions for multiple cutting applications

### Tri-Fold™ Saws

#### COMFORTABLE GRIP

Over-molded rubberized grip for a comfortable and secure grip while working

#### SECURELY HOLDS BLADE

Aluminum locking mechanism prevents blade from being removed during use

#### ACCOMMODATES HACKSAW BLADE

Ideal for flush cutting applications or when a hacksaw is not available

#### DIE CAST ALUMINUM CONSTRUCTION

#### NEW DRYWALL BLADE

Fleam Ground tooth form for fast, clean cuts in drywall  
Ground tip to easily pierce drywall  
Cuts both push and pull stroke



Rotate Blade Out



Loosen Knob to Change Blade

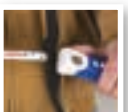

Accommodates Hacksaw Blade

Item No.	Description	EAN	Master Pack	Min. Order Qty
20997EU	Tri-Fold™ Saw with two blades: Multi Material and Drywall blade	082472209976	5	5

### HT50 High-Tension Hacksaw

#### HIGHEST TENSION. EVER

Unique I-beam construction allows blade to tension up to 50,000 psi, resulting in fast, straight cuts

#### COMFORTABLE GRIPS

Rubberized handles allow for confident handling even in wet or cold environments

#### CONVERT TO A JAB SAW

Accepts any LENOX® Recip blade to be used as a jab saw

#### CONVENIENT BLADE STORAGE

Store up to 5 extra 12" hacksaw blades in the I-Beam



Tension



Use as a Jab Saw



Stores up to 5 Blades



Comfort Grips

Item No.	Description	EAN	MasterPack	Min. Order Qty
10507542	HT50 high-tension Hacksaw, 300mm	5706915075427	5	5

## 88300 Lightweight Hacksaw

### HIGH TENSION

Saw will tension up to 30,000 PSI

### EASILY ADJUST TENSION

### ERGONOMIC GRIP

Front handle grip reduces fatigue in continuous cutting applications

### MULTI-PURPOSE

Mount blade at 45 degrees for flush cutting applications



Flush Cutting



Comfortable Grip

Item No.	Description	EAN	MasterPack	Min. Order Qty
10507543	88300 Lightweight Hacksaw, 300mm	5706915075434	5	5



**NEW**

### Double-Sided Hacksaw Blades

2 Cutting Edges in 1 Blade

**DUAL CUTTING EDGES**

Up to 2X longer blade life vs. a single sided hacksaw blade

**DURABLE BI-METAL DESIGN**

Dual high-speed steel cutting edges provide maximum blade durability

**PATENTED "ARROW" BLADE DESIGN**

Ensures proper blade orientation when mounting on the hacksaw frame



Item No.	Description	EAN	Master Pack	Min. Order Qty Blades/Pk.*
1906050	218HE 300 x 13mm 18TPI Double-Sided	0885363075229	650	50
1906241	224HE 300 x 13mm 24TPI Double-Sided	0885363075236	650	50
1871568	218HE 300 x 13mm 18TPI Double-Sided	0885363074383	500	10
1871612	224HE 300 x 13mm 24TPI Double-Sided	0885363074413	500	10



### T2™ TECHNOLOGY HACKSAW BLADES

**T2™ TECHNOLOGY**

A revolutionary new blade design that delivers up to 100% longer blade life versus the prior generation of LENOX® hacksaw blades

**SHATTER RESISTANT**

Bi-metal construction allows blades to bend and flex without breakin

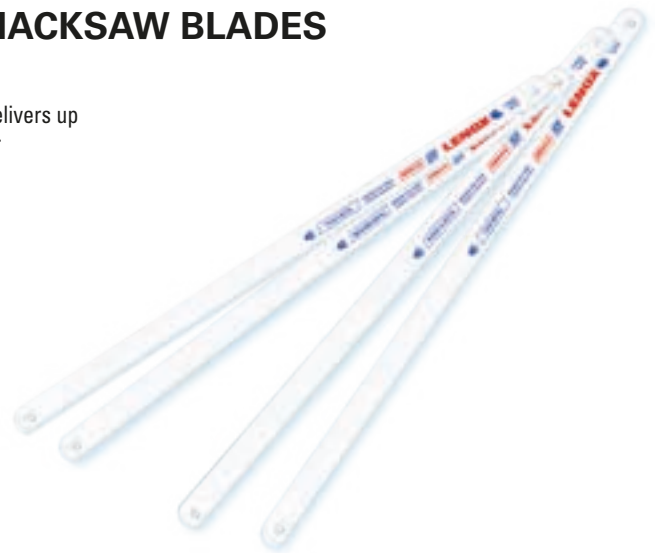

**Shatter resistant:** Bi-Metal construction allows blades to bend and flex

### Bi-Metal Hacksaw Blades



Item No.	Description	EAN	Master Pack	Min. Order Qty Blades/Pk.*
20116218HE	218HE 300 x 13mm 18TPI	082472201161	500	100
20117224HE	224HE 300 x 13mm 24TPI	082472201178	500	100
20118232HE	232HE 300 x 13mm 32TPI	082472201185	500	100
20143V214HE	V214HE 300 x 13mm 14TPI	082472201437	500	10
20144V218HE	V218HE 300 x 13mm 18TPI	082472201444	500	10
20145V224HE	V224HE 300 x 13mm 24TPI	082472201451	500	10
20146V232HE	V232HE 300 x 13mm 32TPI	082472201468	500	10

\*Items can only be ordered in multiples of the Min. Order Quantity

# Handsaws

## Close Quarter™ Saw & Mini Hacksaw Frame

### RUGGED DESIGN

Heavy duty aluminum handle

### FITS IN TIGHT SPOTS

Allows for flush cutting applications



Item No.	Description	EAN	Master Pack	Min. Order Qty
20975975	975 Hacksaw with 250mm bi-metal blade, also fits 300mm blades	082472209754	45	5

## PVC/ABS Plastic Pipe Handsaw

### CUTS PLASTIC PIPE EASILY

Cutting teeth cut on the pull stroke and not on the push stroke for safety

### COMFORTABLE GRIPS

Rubberized handles allow for confident handling even in cold, hot, wet or dirty environments

### FLUSH CUTTING OPTION

Easily mount the blade on the bottom of handle for flush cutting applications



Comfortable Handle



One Step Flush Cuttings

Item No.	Description	EAN	Master Pack	Min. Order Qty
20985HSF12	300mm blade & handle, 10TPI	082472209853	-	5
20980HSF18	450mm blade & handle, 10TPI	082472209808	-	5
20982HSB12	300mm replacement blade, 10TPI	082472209822	50	5
20981HSB18	450mm replacement blade, 10TPI	082472209815	50	5

**Breezes through material:** Unique pull cutting teeth cut quickly through all plastic pipe and wood

**Durable blade:** Rigid carbon blade with hardened teeth for long life

**Comfortable handle:** Large opening for work gloves



**Perfect cuts. Straight and easy.**

Specifically designed jaw holds pipe in place while cutting with stainless steel blade

**Comfortable grips**

Rubberized handles allow for confident cutting even in wet or dirty environments

**Easy open & close**

Conveniently positioned release button allows for true one-handed operation of ratcheting cutter, while locking tab secures blade in place



The blade on the LENOX® Plastic Tubing Cutters is made with serrated stainless steel that requires 25% less cutting force than other cutters on the market; providing a straight, burr-free cut. The specifically designed jaw holds pipe in place while cutting with the serrated stainless steel blade.

### R1 PVC Tube Cutter

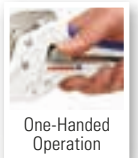
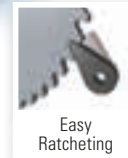
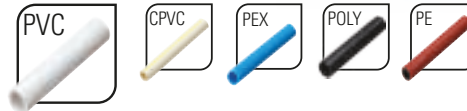

**SPRING LIFE TESTING**

Spring failure is typically catastrophic to a plastic tubing cutter tool. Rather than replacing the spring, a user typically replaces the tool itself.

LENOX® performed tests on the Plastic Tubing Cutter spring testing rig to determine spring life. After 153,632 cycles, the cutters were removed from the rig. And after those 153,632 cycles, the springs still functioned perfectly. It would take an average user more than 10 years of consistent use to make that amount of cuts.

Cuts up to 1-1/4" nominal (1-5/8" Max. OD - 42mm)

For all types of plastic tubing like PVC, CPVC, PEX, PE & PB tubing, flexible hose

Item No.	Description	EAN	Master Pack	Min. Order Qty
10507481	R1 PVC Cutter, 42mm	5706915074819	10	1
10507533	R1B-PVC Replacement Blade	5706915075335	25	1

### R2 PVC Tube Cutter

**Perfect Cuts. Straight And Easy.**

Specifically designed jaw holds pipe in place while cutting with high-carbon steel blade

**One-Handed Ratcheting**

One of the only large diameter cutters than can be ratcheted with just one hand

**Easy Open**

Pull both handles apart to quickly start the next cut

**Cuts Up To 2" Nominal**

(2-3/8" MAX. OD - 60mm)

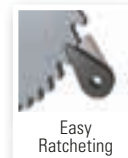
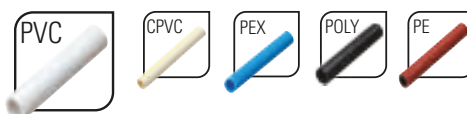

For all types of plastic tubing like PVC, CPVC, PEX, PE & PB tubing, flexible hose

Item No.	Description	EAN	Master Pack	Min. Order Qty
10507482	R2 PVC Cutter, 60mm	5706915074826	-	1
10507534	R2B-PVC Replacement Blade	5706915075342	25	1

## S1 PEX Tube Cutter



**Perfect Cuts. Straight And Easy.**  
Serrated stainless steel blade requires less force to make a cut, leaving a flush end

**Comfortable Grips**  
Rubberized handles allow for confident cutting even in wet or dirty environments

**Easy Open & Close**  
Conveniently positioned locking latch allows for true one-handed operation of spring-loaded cutter

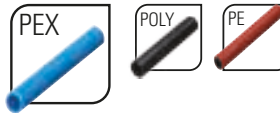

**Cuts up to 1" nominal**  
(1-5/16" max. OD - 33mm)

**For all types of plastic tubing** like PEX, PE & PB tubing, flexible hose.

Item No.	Description	EAN	Master Pack	Min. Order Qty*
10507479	S1 PEX Cutter, 33mm	5706915074796	20	5
10507484	S1B-PEX Replacement Blade	5706915074840	25	1

## S2 CPVC Tube Cutter



**Perfect Cuts. Straight And Easy.**  
High carbon steel blade cuts rigid plastic tubing with a single cut

**Comfortable Grips**  
Rubberized handles allow for confident cutting even in wet or dirty environments

**Durable Construction**  
Cast aluminum body stands up to rugged, repeated use

**Easy Open & Close**  
Conveniently positioned locking latch allows for true one-handed operation of spring-loaded cutter.

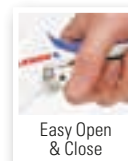
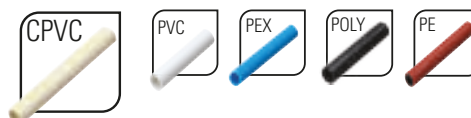

**Cuts up to 1" nominal**  
(1-5/16" max. OD - 33mm)

**For all types of plastic tubing** like PVC, CPVC, PEX, PE & PB tubing, flexible hose

Item No.	Description	EAN	Master Pack	Min. Order Qty*
10507480	S2 CPVC Cutter, 33mm	5706915074802	20	5
10507532	S2B-CPVC Replacement Blade	5706915075328	25	1

\*Items can only be ordered in multiples of the Min. Order Quantity

## CU-INOX PRO Tube Cutter

The LENOX® Cu-INOX Pro Tube Cutters are heavy-duty, high precision tube cutters with telescopic action. With a zinc die-cast body and stainless steel rollers (4 rolls for better grip of the tube).

**Material:**

- Copper (Al + Cu for fast cuts) for max. tube wall thickness: 2mm
- INOX (Stainless Steel) for max. tube wall thickness: 2.5mm



The Multi 67 Tubing Cutter can be used on plastic tube and Multi-layer pipes up to 67mm as well as applicable for copper tubes and stainless steel pipes.

**WON'T WALK WHILE CUTTING**

Four roller tracking system keeps tube from threading

**PROFESSIONAL DEBURRING**

Cleanly and easily deburr pipes with the replaceable machinist's reamer

**WILL NOT DAMAGE CUTTING WHEELS**

Full-stop feed system prevents wheels and rollers from coming into contact

**EASY TO USE**

Change out wheels quickly & easily

**CONVENIENT STORAGE**

Store an extra cutting wheel in the handle



10507460



10507461



10507462



Item No.	Description	Cutting Size	EAN	Master Pack	Min. Order Qty
10507460	CU-INOX PRO 35	3-35mm	5706915075604	30	1
10507461	CU-INOX PRO 45	3-45mm	5706915075611	30	1
10507462	CU-INOX MULTI 67	6-67mm	5706915074628	15	1

## Mini Tube Cutters

LENOX® Mini Tube Cutters are lightweight with an ergonomic knob and optimal tool size. The ideal solution for cutting tubes in difficult-to-access spaces.



10507457

10507458

10507459



Item No.	Description	Cutting Size	EAN	Master Pack	Min. Order Qty
10507457	CU-INOX MINI 16	3-16mm	5706915074574	60	1
10507458	CU-INOX MINI 25	3-25mm	5706915074581	60	1
10507459	CU-INOX MINI 30	3-30mm	5706915074598	60	1

### LESS BURR. MORE CUTS.

Optimized blade geometry of shock-resistant steel

### COMPACT DESIGN FOR TIGHT SPOTS

Non-slip grooved cast body only needs 1/2" clearance to cut

### NO RUSTING

Stainless steel rollers protect the cutter from corrosion

### QUICK IDENTIFICATION

Color coding for easy tool recognition and cutting direction

## Close Quarter Tube Cutters

Single-action automatic tube cutting. These close quarter cutters are ideal for optimal accessibility in tight and confined spaces, even tight against a wall. Cuts copper with only a few turns. The cutter tightens onto the tube, cutting as you twist, without adjusting. Spare Wheels available.



**Tightens onto the tube.** Cutting as you twist, without adjusting

Item No.	Description	Cutting Size	EAN	Master Pack	Min. Order Qty
10507464	CQ12	12mm	5706915074642	64	4
10507975	CQ14	14mm	5706915079753	64	4
10507465	CQ15	15mm	5706915074659	64	4
10507466	CQ16	16mm	5706915074666	64	4
10507467	CQ18	18mm	5706915074673	64	4
10507468	CQ22	22mm	5706915074680	64	4
10507469	CQ28	28mm	5706915074697	64	4

## Spare Cutting Wheels, 4 Pack



Item No.	Description	Fits Cutter	EAN	Master Pack	Min. Order Qty Wheels / Pack*
10507470	Cu-Al WHEEL	Multi 67/ PRO/ MINI 30	5706915074703	-	4
10507471	PVC WHEEL	Multi 67	5706915074710	-	4
10507472	INOX WHEEL	Multi 67/ PRO/ MINI 30	5706915074727	-	4
10507473	CQ WHEEL	CQ12-28	5706915074734	-	4
10507967	Cu-Al / INOX WHEEL	MINI 16/MINI 25	5706915079678	-	4

\*Items can only be ordered in multiples of the Min. Order Quantity

ITEM NO.	PAGE	ITEM NO.	PAGE	ITEM NO.	PAGE	ITEM NO.	PAGE	ITEM NO.	PAGE	ITEM NO.	PAGE
21060656GR	5	20185812114R	7	3004848L	13	3024141CT	15	12149DG300S	21		
21062956GR	5	20598966R	7	3005050L	13	3024242CT	15	20997EU	22		
21061156GR	5	20500106R	7	3005252L	13	3024343CT	15	148216J6R	22		
21064610GR	5	20597960R	7	3005454L	13	3024848CT	15	10507542	22		
21065810GR	5	20372960R5	7	3005656L	13	3025252CT	15	10507543	23		
21066414GR	5	20523B966R	7	3005858L	13	3025454CT	15	1906050	24		
21067614GR	5	20524B960R	7	3006060L	13	3025656CT	15	1906241	24		
21068418GR	5	20592650R	8	3006262L	13	3025858CT	15	1871568	24		
21069618GR	5	20374650R5	8	3006464L	13	3026060CT	15	1871612	24		
21070818GR	5	20577850R	8	3006666L	13	3026464CT	15	1906050	24		
21071424GR	5	20515B850R	8	3006868L	13	3026666CT	15	1906241	24		
21072624GR	5	121439KPE	8	3007070L	13	3026868CT	15	1871568	24		
21073824GR	5	1214412RKD	8	3007272L	13	3027272CT	15	1871612	24		
210886066GR	5	1497913RKM	8	3007474L	13	3027676CT	15	20116218HE	24		
21089960GR	5	1498013RKW	8	3007676L	13	3028080CT	15	20117224HE	24		
21090966GR	5	1073415RKG	8	3008080L	13	3028888CT	15	20118232HE	24		
21091106GR	5	10833800RDG	9	1816243	13	3029696CT	15	20143V214HE	24		
210926108GR	5	1766338	9	3008888L	13	30297123CT	15	20144V218HE	24		
210969108GR	5	1766356	9	1816245	13	3029865CTPD	15	20145V224HE	24		
210936110GR	5	20505600RG	9	3009696L	13	10507941	15	20146V232HE	24		
210979110GR	5	20506100RG	9	3106106L	13	1779771	15	20975975	25		
2110012110GR	5	20576800RG	9	3112112L	13	1779810	15	20985HSF12	25		
210946114GR	5	205966565RCT	9	3132132L	13	3084310X	15	20980HSF18	25		
210989114GR	5	205998535RCT	9	1768436	13	3084712X	15	20982HSB12	25		
2110112114GR	5	21103235BLP	10	1768556	13	3084818X	15	20981HSB18	25		
210956118GR	5	21104300BLP	10	1768559	13	30857AA1	15	10507481	26		
210999118GR	5	21105450BLP	10	1768662	13	1768811	16	10507533	26		
2110212118GR	5	21107300LC	10	1768668	13	1768812	16	10507482	26		
20550414R	6	21108450LC	10	1768695	13	1768813	16	10507534	26		
20552418R	6	10729810RPC	10	1768696	13	1779774	16	10507479	27		
20554424R	6	10730101ORPC	10	1768698	13	1779801	16	10507484	27		
20575634R	6	20427424T	10	1768793	13	1779802	16	10507480	27		
20556676R	6	20428432T	10	1768794	13	1779803	16	10507532	27		
20560606R	6	300099L	12	1768795	13	1779804	16	10507460	28		
20572656R	6	3001010L	12	10507823	14	1779805	16	10507461	28		
20570636R	6	3001111L	12	10507824	14	1779806	16	10507462	28		
148216J6R	6	3001212L	12	10507825	14	68040LN	16	10507457	29		
20582956R	6	3009820MMHS	12	10507826	14	68047	16	10507458	29		
20585156R	6	3001313L	12	10507827	14	68080	16	10507459	29		
20562610R	6	3001414L	12	10507828	14	30960MVB412	19	10507464	29		
20580810R	6	3001515L	12	10507829	14	30961MVB1424	19	10507975	29		
20583110R	6	3001616L	12	10507830	14	30962MVB618	19	10507465	29		
20564614R	6	3001717L	12	10507831	14	30963MVB2034	19	10507466	29		
21519814R	6	3001818L	12	10507832	14	30964MVB528PG	19	10507467	29		
20566618R	6	3001919L	12	10507833	14	30882VB2	19	10507468	29		
20578818R	6	3002020L	12	10507834	14	30883VB3	19	10507469	29		
21510118R	6	3002121L	12	10507835	14	30912VB12	19	10507470	29		
20568624R	6	3002222L	12	10507836	14	20305BT406S	20	10507471	29		
20579824R	6	3002323L	12	10507837	14	20306BT410S	20	10507472	29		
20530B656R	6	3002424L	12	10507838	14	20309BT686S	20	10507473	29		
20558B956R	6	3002525L	12	10507839	14	20311BT320	20	10507967	29		
20590B810R	6	3002626L	12	10507840	14	20313BT450	20				
20493B610R	6	3002727L	12	10507841	14	20314BT450	20				
20491B110R	6	3002828L	12	10507842	14	20315BT456	20				
20494B614R	6	3002929L	12	3021111CT	15	20301BT314S	20				
20529B618R	6	3003030L	12	3021212CT	15	20302BT318S	20				
20487B818R	6	3003232L	12	3021414CT	15	20303BT324S	20				
21511B118R	6	3003333L	12	3021616CT	15	20308BT518S	20				
1769340	7	3003434L	12	3021818CT	15	20803BT332S	20				
1769341	7	1816241	12	3022020CT	15	20812B406S	20				
201706110R	7	3003636L	12	3022222CT	15	20813B410S	20				
201726114R	7	3003838L	12	3022424CT	15	20814B450S	20				
201746118R	7	1816242	13	3022626CT	15	20295CF450	21				
201769110R	7	3004040L	13	3022828CT	15	20296CF450	21				
201789114R	7	3004141L	13	3023232CT	15	20298CFS406S	21				
201809118R	7	3004242L	13	3023434CT	15	20312BT416	21				
2018212110R	7	3004343L	13	3023636CT	15	20299CF320	21				
2018412114R	7	3004444L	13	3023838CT	15	1802081	21				
2019012118R	7	3004646L	13	3024040CT	15	20300GT300S	21				



V, 5bâ^•d^ à~ d !K



Ô^} d a p a ^ & @ ð : } æ Ò Š V Ò Ô P Á Ú ] Ë Á È È

~ | Ë Ò ò a ! ^ & } æ Æ Ë Ë Á Ì È € € Á , ã } ð æ æ  
c | Ë È Ì Á Ì Á Ì Ì Á Ì Á € € Á æ æ Æ Ì Á Ì Á Ì Ì Á Ì Á € €

^ | c & @ ^ | c & @ ð { È | Á Á , , È | c & @ ð { È |

**NWL Austria GmbH**

Schottenring 14,  
A-1010 Vienna  
Austria  
Tel: +43 (0)1206 09 1075

**NWL Belgium B.V.B.A**

Industriepark-Noord 30  
Sint-Niklaas 9100  
Belgium  
Tel: +32 22008352 / +3222008353  
+3222008354 / +3222008355

**Newell Rubbermaid  
Czech Republic s.r.o.**

Perlova 5  
Prague 110 00  
Czech Republic  
Tel: +420239014996

**NWL Denmark Aps**

Stamholmen 155, 2nd floor  
2650 Hvidovre  
Denmark  
Tel: +4543682212

**NWL Finland OY**

c/o Attorneys at Law Borenus Ltd  
Yrjonkatu 13A  
Helsinki 00120  
Finland  
Tel: +358972519252

**NWL France S.A.S**

122 Avenue du Général Leclerc,  
92100 Boulogne Billancourt  
France  
Tel: + 33 (0) 157 323 572

**NWL Germany GmbH**

Albert-Einstein-Ring 17-21  
22761 Hamburg  
Germany  
Tel: +49 (0)69 380 789 437

**Newell Rubbermaid  
Hungary Trading Ltd.**

Csorsz u. 59-51  
H-1124 Budapest  
Hungary  
Tel: +3617779880

**NWL Italy Srl**

Viale Edoardo Jenner 55  
Milan 20159  
Italy  
Tel: +39 (0) 029 129 4743

**NWL Luxembourg S.à r.l**

412F route d'Esch  
L-1030  
Luxembourg  
Tel: +33 (0) 157 323 572

**NWL Netherlands B.V.**

Grasbeemd 6  
5705 DG Helmond  
The Netherlands  
Tel: +31202061635 / +31202061636  
+31202061637 / +31202061638

**NWL Norway Oy**

c/o Advokatfirma DLA Piper  
Norway DA  
Olav vs gate 4  
Oslo 0114  
Norway  
Tel: +4724159924

**Newell Poland Services Sp. z o.o.**

61-894 Poznań  
Plac Andersa 7  
Poland  
Tel: +48223060213

**Newell Spain, S.L.**

Av. Burgos 12, 2ª planta  
28036 Madrid  
Spain  
Tel: +34 910 507 251

**Newell Rubbermaid Sweden AB**

c/o DLA Nordic Box 7315  
Stockholm 1039  
Sweden  
Tel: +46851761670

**Newell Europe Sàrl**

Chemin de Blandonnet 10  
1214 Vernier  
Switzerland  
Tel: +44511 8342 / 43

**Newell Rubbermaid UK Limited**

Halifax Avenue - Fradley Park  
Lichfield Staffordshire WS 13 8SS  
United Kingdom  
Main Tel: +44 (0) 1543 44 70 01  
Customer Service Tel: 0344 412 1190  
Customer Service Fax: 0344 412 1184

**Sanford LLC**

Letnikovskaya Street 2, Building 1,  
Moscow 115114  
Russian Federation  
Tel: +48 61 63 98 153

**Newell Rubbermaid Kırtasiye Ticaret  
ve Sanayi Limited Sirketi**

Huzur Mah Fazil Kaftanoglu Cad.  
No. 7/1 Seba İş Merkezi, Seyrantepe  
Sisli  
Istanbul, Turkey  
Tel: +48 61 63 98 160

**Newell Rubbermaid Middle East FZE**

Dubai Airport Free Zone Building 6W  
Block B, Office 640, P O Box 54554  
Dubai, United Arab Emirates  
Tel: +48 61 63 98 160

**NWL South Africa (Pty) Limited**

150 Fleming St.,  
Meadowdale Gauteng 1614  
South Africa  
Tel: +48 61 63 98 160